

# PCI Bus Architecture

By

S.Senthilmurugan

Asst.Professor/ICE

SRM University. Chennai.

# Introduction

- Introduction
- History of the Bus
- Performance
- Plug and Play
- How it works
- Other types of the PCI Bus
- Future of the PCI Bus
- Conclusion

# Introduction

- A computer bus is used to transfer data from one location or device on the motherboard to the central processing unit where all calculations take place.
- Two different parts of a Bus
  - Address bus-transfers information about where the data should go
  - Data bus-transfers the actual data

# History

- PCI(Peripheral Component Interconnect) bus is based on ISA (Industry Standard Architecture) Bus and VL (VESA Local) Bus.
- Introduced by Intel in 1992
- Revised twice into version 2.1 which is the 64-bit standard that it is today.
- Great feature of PCI Bus was that it was invented as an industry standard
- PCI provides direct access to system memory for the devices that are connected to the bus which is then connected through a bridge that connects to the front side bus.
- This configuration allowed for higher performance without slowing down the processor

# History

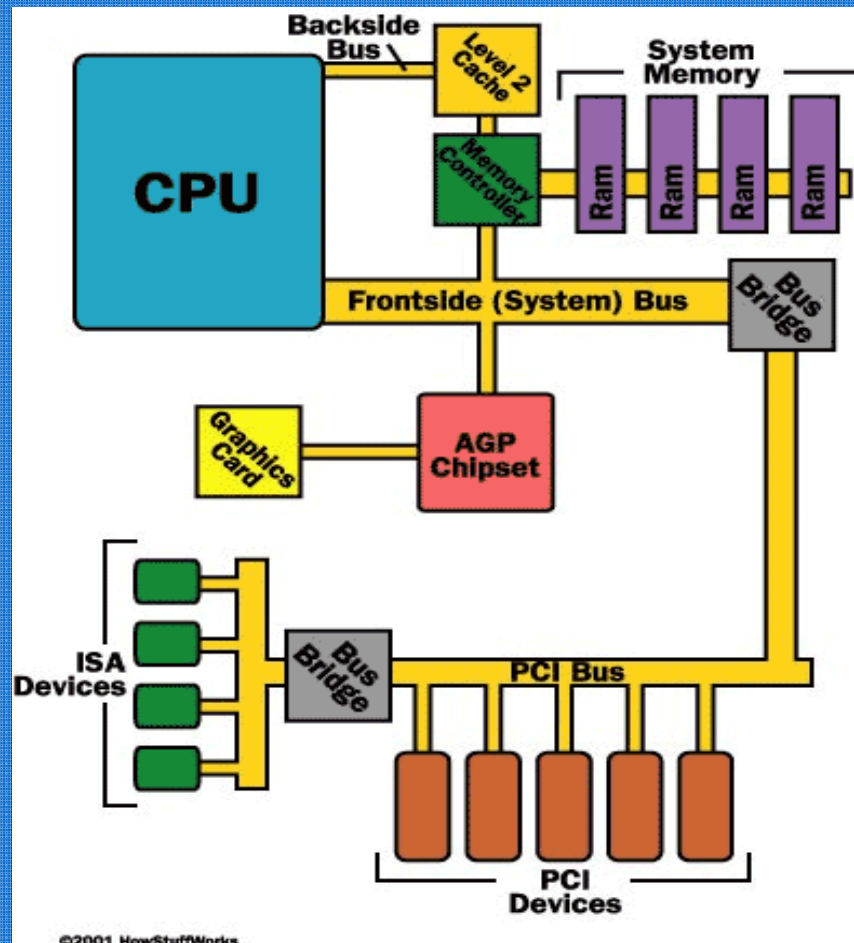

- The PCI Bus was originally 33Mhz and then changed to 66Mhz.
- PCI Bus became big with the release of Windows 95 with “Plug and Play” technology
- “Plug and Play” utilized the PCI bus concept.

# PCI System Bus Performance

- What makes the PCI bus one of the fastest I/O bus used today?
- Three features make this possible:
  - Burst Mode: allows multiple sets of data to be sent (Kozierok, 2001a)
  - Full Bus Mastering: the ability of devices on the PCI bus to perform transfers directly (Kozierok, 2001c)
  - High Bandwidth Options: allows for increased speed of the PCI (Kozierok, 2001a)

# How PCI Compares to Other Buses

Bus Type	Bus Width	Bus Speed	MB/sec	Advantages	Disadvantages
ISA	16 bits	8MHz	16 MBps	low cost, compatibility, widely used	low speed, Jumpers & DIP switches. becoming obsolete
PCI	64 bits	133 MHz	1 GBps	very high speed, Plug & Play, dominant board-level bus	incompatible with older systems, can cost more
CompactPCI	64 bits	33MHz	132 MBps	designed for industrial use, hot swapping/Plug & Play, ideal for embedded systems	lower speed than PCI, need adapter for PC use, incompatible with older systems

Table 1: How PCI compares to other buses (Tyson, 2004a; Quatech, 2004c)

# Plug and Play

- Requirements for full implementation:
  - Plug and Play BIOS
  - Extended System Configuration Data (ESCD)
  - Plug and Play operating system
- Tasks it automates:
  - Interrupt Requests (IRQ)
  - Direct Memory Access (DMA)
  - Memory Addresses
  - Input/Output (I/O) Configuration

(Tyson, 2004b)



# How PCI Works: Installing A New Device

- Once a new device has been inserted into a PCI slot on the motherboard
  1. Operating System Basic Input/Output System (BIOS) initiates Plug and Play (PnP) BIOS.
  2. PnP BIOS scans the PCI bus for any new hardware connected to the bus. If new hardware is found, it will ask for identification.
  3. The device will respond with its identification and send its device ID to the BIOS through the bus.
  4. PnP checks the Extended System Configuration Data (ESCD) to make sure the configuration data already exists for the card. (If the card is new, then there will be no data for it.)

## New Device Cont...

5. PnP will assign an Interrupt Request Line, Direct Memory Access, memory address and Input/Output settings to the card, then stores the information in the ESCD.
6. When the Windows software loads, it will check the PCI bus and the ESCD to see if there is new hardware. Windows will alert the user that new hardware has been found if there is new hardware installed and will also identify the hardware.
7. Windows will determine the device and attempt to install its driver. The operating system may ask the user to insert a disk containing the driver or direct it to where the driver is located. In the event that Windows is unable to determine what the device is, it will provide a dialog window so the user can identify the hardware and load its driver.

# How a Device Works

- Example: PCI-based sound card
  1. The sound card will convert the analog signal to a digital signal.
  2. The digital audio data carried across the PCI bus to the bus controller, which determines which device on the PCI device has the priority to send data to the central processing unit (CPU) and whether the data will go directly to the CPU or to the system memory.
  3. If the sound card is in recording mode, the bus controller will assign a high priority to the data coming from the sound card. It will send the sound cards data over the bus bridge to the system bus.
  4. The system bus will save the data in system memory. When the recording is complete, then it will be up to the user to save the data from the sound card on either the hard drive, or will remain in memory for additional processing.

## Other Types of PCI

- Original PCI
- PCI 2.3
- PCI-X
  - PCI-X 2.0 (second revision)
- PCI Express



Figure: PCI-X 2.0 card

([http://ch272.thinkquest.hostcenter.ch/cgi-local/community.pl?action=pc\\_theme&lang=ge](http://ch272.thinkquest.hostcenter.ch/cgi-local/community.pl?action=pc_theme&lang=ge))

## Future of PCI: Requirements

- Support multiple market segments
- Backwards compatible
- Scalable performance
- Advanced features including QoS, power management, and data integrity

# PCI Express Solution

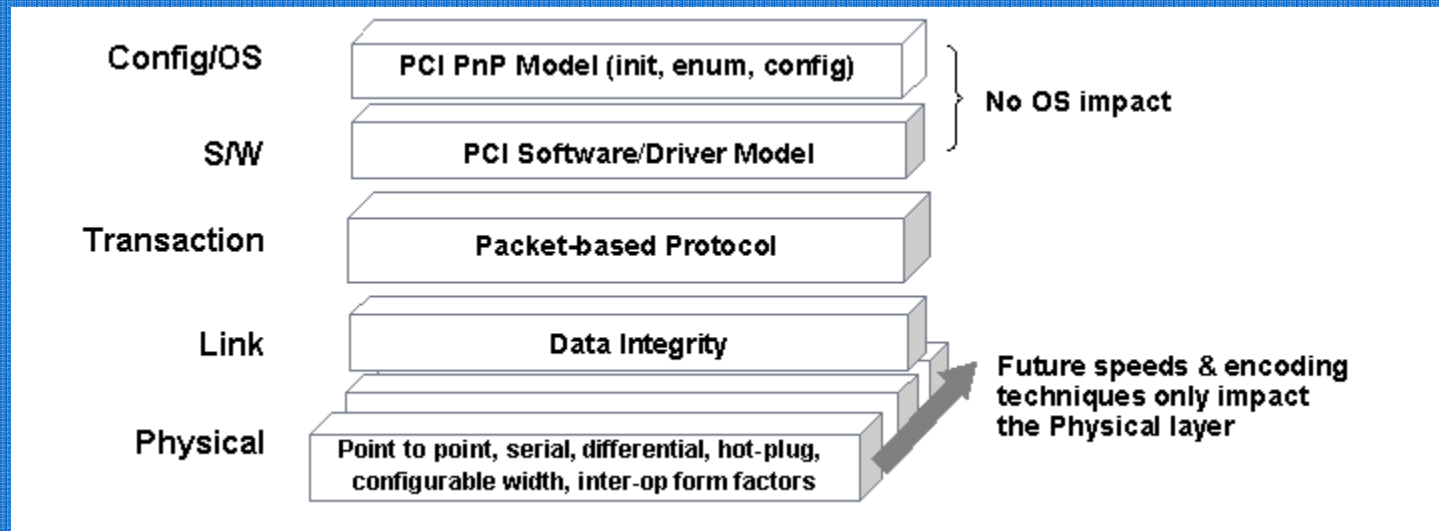

# Advanced Switching with PCI express

- Signals take place at link level
- Allows for QoS and fan out capabilities
- Utilizes system bandwidth

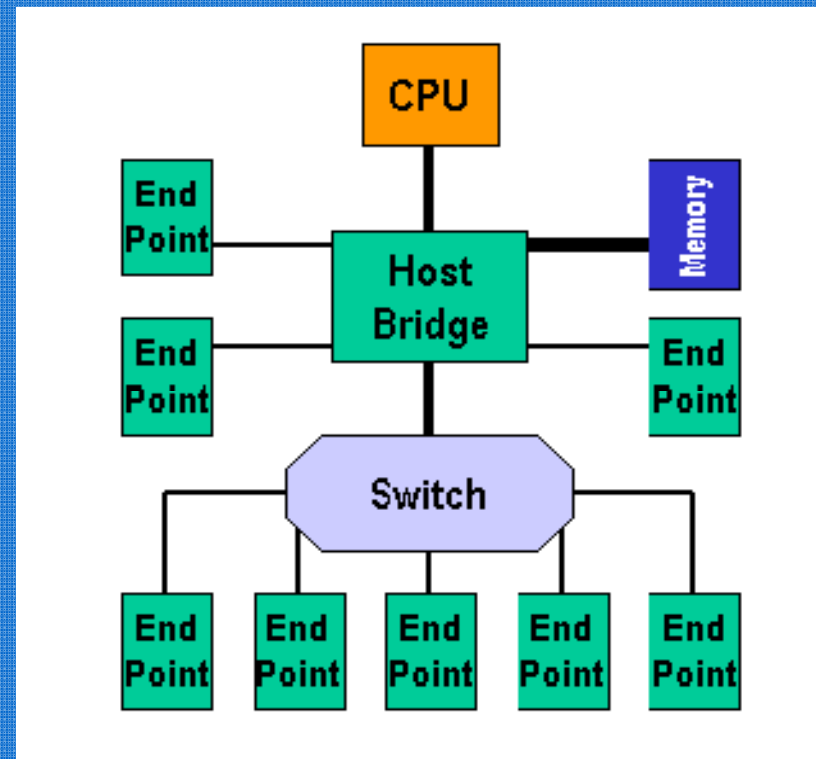

## Conclusion

- Due to the need for growing data transfer rates among IO devices, the original PCI Architecture has become outdated
- A new model of PCI, called PCI Express will replace the dated architecture giving it life for another decade



End of Presentation

Any Questions?