

15EI203J-Transducer Engineering

N.Deepa

A.P(Sr.G)

SRM University,

deepa.n@ktr.srmuniv.ac.in

Unit 1-Measurement and Instrumentation of Transducers

General Configuration And Description Of Measurement And Instruments

MEASUREMENT

- Measurement is a process by which the physical parameters are converted to meaningful numbers.

Unknown quantity → predefined standard
(compared)

- The measuring process is one in which the property of an object or system under consideration is compared to an accepted standard unit, a standard defined for that particular property.

Basic requirements for meaningful measurement

- Standard used for comparison—accurately defined, commonly accepted
- Apparatus used ,Method adopted--provable

SIGNIFICANCE OF MEASUREMENT

- Advancement of progress science and technology (depend on) → Parallel in measurement techniques
- **Major function of Engg. Branches:-**
 1. Design of equipment process } Needs Measurement
 2. Proper operation and maintenance of equipments
- **Basic Methods Of Measurement:-**
 1. Direct method
 2. Indirect method

DIRECT COMPARISON METHOD

- Unknown quantity is compared directly with a primary or secondary standard
 - Primary Standards—Maintained by national standard laboratories in different parts of the world for various quantities like length, mass, time etc. Accuracy -10^8
- Secondary standard –Basic reference standard used in industrial measurement laboratories. Accuracy- 10^6

INDIRECT COMPARISON METHOD

- Unknown quantity is compared with a standard or meter which is compared or checked with a primary or secondary standard which are kept in national laboratories periodically.
- Eg:- Measurement of voltage using a voltmeter which is periodically calibrated with a primary or secondary standard

INSTRUMENTS

Measurement involve the use of instruments as a physical means of determining quantities or variables.

Measurement System- Measuring instrument consists of several elements.

Three essential elements of instruments

- A detector
- A intermediate transfer device
- An indicator/recorder/storage device

PHASES OF INSTRUMENTS

1. Mechanical instruments
2. Electrical instruments
3. Electronics instruments

FUNCTIONS OF INSTRUMENT AND MEASUREMENT SYSTEMS

- Indicating function
- Recording function
- Controlling function

APPLICATIONS OF MEASUREMENT SYSTEM

- Monitoring of process and operation
- Control of process and operation
- Experimental Engineering Analysis

ELEMENTS OF A GENERALISED MEASUREMENT SYSTEM

- Systematic organization and analysis of measurement systems in necessary.
- INSTRUMENT- Device which is designed to maintain a functional relationship between prescribed properties of physical variables and must include ways and means of communication to human observe.
- Validity of functional relationship-As long as the static calibration remains constant.
- **The three main functional elements are-**
 1. Primary sensing Element
 2. Variable conversion Element
 3. Data presentation Element

Generalized Scheme For Measurement Systems

Elements Of Generalized Measurement System

- **Instrument-** The device which is designed to maintain a functional relationship between prescribed properties of physical variables and must include ways and means of communication to human observation. The three main functional elements are:
 - Primary sensing element
 - Variable conversion element
 - Data presentation element

Generalized block diagram of measuring system

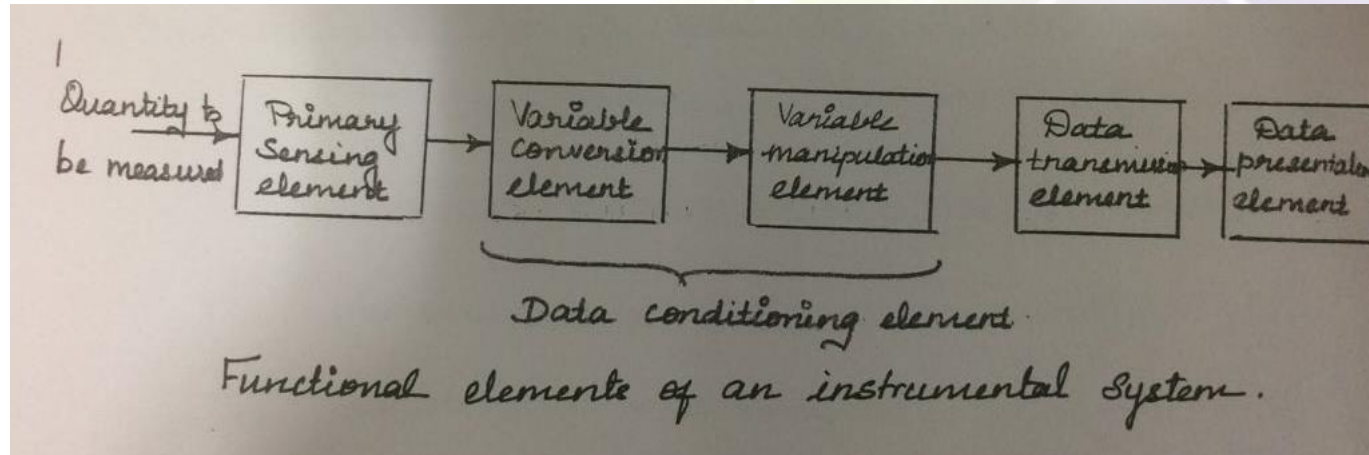

- **Primary Sensing Element:** The quantity under measurement makes it first contact with this element- Measurand is first detected by a primary sensor. The act is followed by a transducer which converts physical quantity into electrical quantity.
- **Variable Conversion Element:** It may be a voltage, frequency or some other electrical parameter. For the instrument to perform the desired function, it may be necessary to convert this output to suitable form while preserving the information content of original signal.

- **Variable Manipulation Element:** The function is to manipulate the signal presented to it preserving the original nature of the signal.

Example: Electronic Amplifier

- **Data Transmission Element:** When the elements of the instruments are actually separated physically, it becomes necessary to transmit data from one to another.

Example: Controls are sent from earth control stations to spacecrafts by complicated telemetry systems.

- **Data Presentation Element:** The information about the quantity under measurement has to be conveyed to the personnel handling the instrument for monitoring, control or analysis purpose.

Example: Bourdon Tube Pressure Gauge

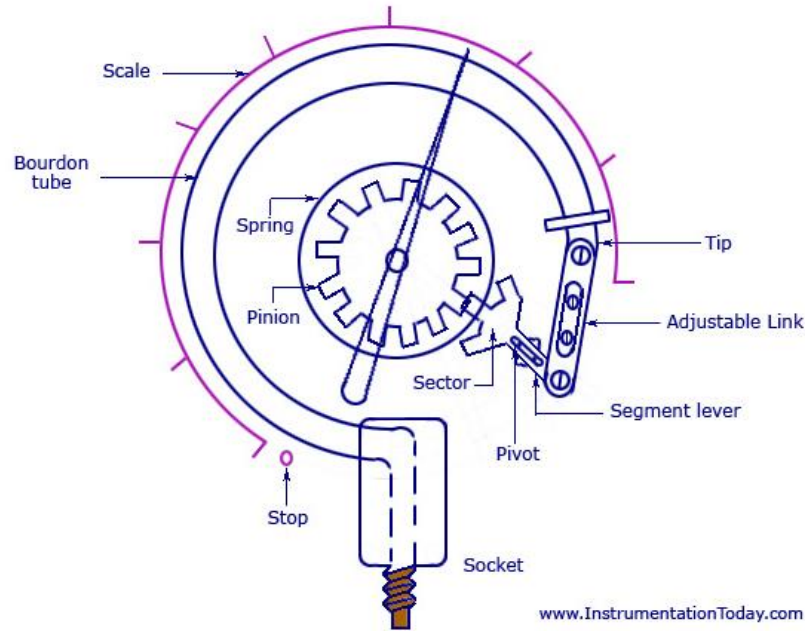

Bourdon Tube Pressure Gauge

Schematic Diagram of a Bourdon Tube

UNITS AND STANDARDS REQUIREMENT OF TRANSDUCERS

UNITS

- Standard measure of each kind of physical quantity.
- The result of a measurement of physical quantity must be defined both in kind and magnitude.

TYPES OF UNITS



FUNDAMENTAL UNITS

- A system of units are independently choosen.

DERIVED UNITS

- Remaining units are called derived units.

SYSTEM OF UNITS

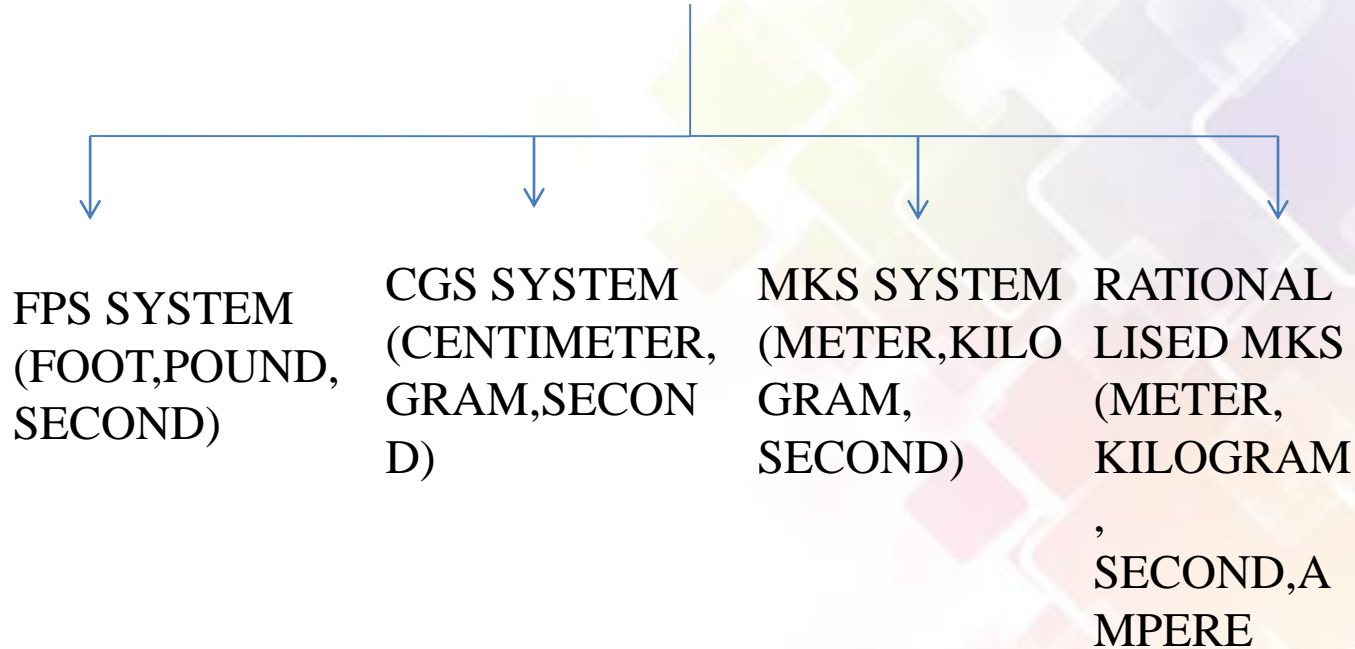

ADVANTAGES OF MKS SYSTEM

- This system connects the practical units directly with the fundamental laws of electricity and magnetism.
- It gives specified formulae for expression of electromagnetism involving only practical units.

ADVANTAGES OF SI UNITS

- It is a rational system.
- It is a coherent system of units.
- It is a decimal system.



STANDARDS

Standards-

- It is a physical representation of a unit of measurement.
- It is applied to a piece of equipment having a known measure of physical quantity.
- It is developed for other units of measurements including fundamental units as well as for some of the derived mechanical and electrical units.



Classification Of Standards-

Standards are classified by their functions as-

- 1> International standards
- 2> Primary standards
- 3> Secondary standards
- 4> Working standards

International Standards –

- >It is maintained by International Bureau of weights and measures.
- >It is not available for ordinary users.
- >It represents the units of measurement which are closest to the possible accuracy attainable with present day technological and scientific methods.
- >It is checked and evaluated regularly against absolute measurements in terms of fundamental units.



Primary Standards-

- >It is maintained by National Standards laboratory in different parts of the world.
- > The main function of primary standards is the verification and calibration of secondary standard.

Secondary Standards-

- >It is used in Industrial measurement laboratories.
- >It is accessible to all measurement engineers.

Working Standards-

- >It is used to check and calibrate general laboratory instruments for their accuracy and performance.

Fundamental Standards-

- >The four fundamental quantities of the International Measuring system for which independent standards have been defined are : mass, length , time and temperature.

Some Other Common Standards Are:

- > **Electrical Standards**
- > **Standards for luminous intensity**
- > **Standards for pressure**
- Etc**

END

ERRORS

- Errors are defined as the measure of estimated difference between observed or calculated value of a quantity or true value.
- They can only be minimized but not be eliminated completely.
- They interpret the result in an intelligent manner.



TYPES OF ERRORS

Basically three types of errors are studied:-

1. Gross Errors
2. Systematic Errors
 - a. Instrumental Errors
 - b. Environmental Errors
 - c. Observational Errors
3. Random Errors

SYSTEMATIC ERRORS

- INSTRUMENTAL ERRORS- It is due to inherent shortcoming in the instrument or it may occur due to overloading or misuse of the instruments.
- ENVIRONMENTAL ERRORS- It occurs due to external conditions to measuring device like Temperature, Pressure, Humidity, Dust, Vibrations, etc.
- OBSERVATIONAL ERRORS- It occurs due to parallax (apparent displacement when the line of vision is not normal to scale), or wrong scale reading or wrong recording data.

GROSS ERRORS

Gross errors are mainly covers the human mistakes in reading instruments and recording and calculating measurement results.

for example- due to oversight, the read of temperature as 31.5 while the actual reading may be 21.5 .

RANDOM ERRORS

The happenings or disturbances out of which we are unaware of. These unpredictable errors occurs even when all the systematic errors are countered. They cannot be corrected by any method.

REMEDIES

- Large number of readings can be taken by different experiments by different point of time.
- Correction factors should be applied .
- Instrument may be recalibrated carefully.
- Keep the external conditions as constant as possible.



SRM
UNIVERSITY
(Under section 3 of UGC Act 1956)

STATISTICAL METHODS

INTRODUCTION

- **Statistical methods:** Methods of collecting, summarizing, analyzing, and interpreting variable numerical data. Statistical methods can be contrasted with deterministic methods, which are appropriate where observations are exactly reproducible or are assumed to be so.



MEAN

The mean is the average of all numbers and is sometimes called the [arithmetic mean](#).

For example, in a data center rack, five [servers](#) consume 100 watts, 98 watts, 105 watts, 90 watts and 102 watts of power, respectively. The mean power use of that rack is calculated as $(100 + 98 + 105 + 90 + 102 \text{ W})/5 \text{ servers} =$ a calculated mean of 99 W per server.

MEDIAN

- .The statistical median is the middle number in a sequence of numbers. To find the median, organize each number in order by size; the number in the middle is the median.

FOR EXAMPLE:

For the five servers in the rack,
arrange the power consumption
figures from lowest to highest: 90
W, 98 W, 100 W, 102 W and 105
W. The median power
consumption of the rack is 100 W.
If there is an even set of numbers,
average the two middle numbers.



MODE

The mode is the number that occurs most often within a set of numbers.

FOR EXAMPLE:

There is a set of numbers is 90 W, 104 W, 98 W, 98 W, 105 W, 92 W, 102 W, 100 W, 110 W, 98 W, 210 W and 115 W. The mode is 98 W since that power consumption measurement occurs most often amongst the 12 servers.



RANGE

The range is the difference between the highest and lowest values within a set of numbers.

FOR EXAMPLE:

If a six-server rack includes 90 W, 98 W, 100 W, 102 W, 105 W and 110 W, the power consumption range is $110\text{ W} - 90\text{ W} = 20\text{ W}$.

PROBLEM :-

The following 10 observations were recorded when measuring a voltage 41.7, 42.0, 41.8, 42.0, 42.1, 42.9, 42.5, 42.0, 41.9, 41.8. Find i) Mean ii) S.D iii) Probable error of one reading.

x_i	d	d^2
41.7	-0.27	0.0729
42.0	+0.03	0.0009
41.8	-0.17	0.0289
42.0	+0.03	0.0009
42.1	+0.13	0.0169
41.9	-0.07	0.0049
42.5	+0.03	0.0009
42.0	-0.07	0.0049
41.9	+0.53	0.2809
41.8	-0.17	0.0289
419.7		0.441

i) Mean = $\frac{\sum x_i}{N} = \frac{419.7}{10} = 41.97$

ii) S.D = $\sqrt{\frac{\sum d^2}{N-1}} = \sqrt{\frac{0.441}{9}} = 0.221$

iii) Probable error of one reading
 $r_1 = 0.6745(\sigma)$
 $r_1 = 0.1490V$



PROBLEM - 2 :-

One hundred temperature readings were taken at small intervals of time and recorded to the nearest 0.5°C . The frequency of occurrence of the readings is given below.

Temperature readings $^{\circ}\text{C}$	98.5	99	99.5	100	100.5	101.0	101.5
Frequency	4	18	19	35	17	10	2

- Calculate (i) arithmetic mean (ii) average deviation
iii) standard deviation (iv) variance and (v) probable error

SOLUTION :-

i) Arithmetic mean

$$\begin{aligned}\bar{x} &= \frac{x_1f_1 + x_2f_2 + \dots + x_7f_7}{f_1 + f_2 + \dots + f_7} \\ &= \frac{98.5 \times 4 + 99 \times 18 + 99.5 \times 19 + 100 \times 35}{100} \\ &= \frac{9993}{100}\end{aligned}$$

$$\bar{x} = 99.93^{\circ}\text{C}.$$

ii) Deviation from the mean

$$d_1 = 98.5 - 99.93 = -1.43$$

$$d_2 = 99.0 - 99.93 = -0.93$$

$$d_3 = 99.5 - 99.93 = -0.43$$

$$d_4 = 100.0 - 99.93 = +0.07$$

$$d_5 = 100.5 - 99.93 = +0.57$$



$$d_6 = 101.0 - 99.93 = +1.07$$

$$d_7 = 101.5 - 99.93 = +1.57$$

Average deviation, absolute

$$\begin{aligned} D &= \frac{|d_1|f_1 + \dots + |d_7|f_7}{f_1 + f_2 + \dots + f_7} \\ &= \frac{(1.43 \times 4) + (0.93 \times 13) + (0.43 \times 19) + (0.07 \times 35) \\ &\quad + (0.57 \times 17) + (1.07 \times 10) + (1.57 \times 2)}{100} \\ &= \frac{51.96}{100} = 0.5196^\circ\text{C} \end{aligned}$$

$$D = 0.5196^\circ\text{C}$$

iii) Standard deviation

$$\begin{aligned} \sigma &= \frac{d_1^2 f_1 + d_2^2 f_2 + \dots + d_7^2 f_7}{f_1 + f_2 + \dots + f_7} \\ &= \frac{(-1.43)^2 \times 4 + (0.93)^2 \times 13 + (0.43)^2 \times 19 + (0.07)^2 \times 35 \\ &\quad + (0.57)^2 \times 17 + (1.07)^2 \times 10 + (1.57)^2 \times 2}{100} \end{aligned}$$

$$\sigma^2 = \frac{45.01}{100}$$

$$\sigma = 0.671^\circ\text{C}$$

iv) Variance

$$\sigma^2 = 0.4501$$

v) Probable error = $0.6745 \times \sigma$
= $0.6745 \times 0.671 = 0.4526^\circ\text{C}$



PROBLEM - 3

Temperature of a metal bath is measured 100 times with variations in apparatus, procedures and persons. The readings are tabulated below.

Temp °C	397	398	399	400	401	402	403	404	405
Freq	1	3	12	23	37	16	4	2	2

Find i) Mean ii) Mode iii) Mean deviation iv) Standard deviation v) Probable error of one reading.

Temp T_i	Freq f_i	$T_i \times f_i$	$d_i = T_i - \bar{T}$	$ f_i \times d_i $	d_i^2	$f_i d_i^2$
397	1	397	-3.78	3.78	14.2884	14.288
398	3	1194	-2.78	8.34	7.7284	23.185
399	12	4788	-1.78	21.26	3.1684	38.020
400	23	9200	0.78	17.94	0.6084	13.993
401	37	14887	+0.22	8.14	0.0484	1.790
402	16	6432	+1.22	19.52	1.4884	23.814
403	4	1612	+2.22	8.88	4.9284	19.214
404	2	808	+3.22	6.44	10.3684	20.734
405	2	810	+4.22	8.44	17.8084	35.618
	100	40078		102.84		190.656

i) Mean temperature $T = \frac{40078}{100} = 400.78^\circ\text{C}$

ii) Mode = 401°C

iii) Mean deviation = $102.8/100 = 1.028^\circ\text{C}$

iv) Std. deviation (σ) = $\sqrt{(190.65/100)} = 1.38^\circ\text{C}$

v) Probable error of one reading = $0.6745\sigma = 0.93^\circ\text{C}$

Unit 2-Characteristics of Transducers

STATIC CHARACTERISTICS

The main static characteristics are:

- Accuracy
- Sensitivity
- Reproducibility
- Drift
- Static error
- Dead zone
- Precision
- Repeatability
- Dead time
- Threshold

❖ Reproducibility

- Degree of closeness with which the given value may be repeatedly measured.

❖ Drift

- Variation of measured value with time for a given input is called as drift.

❖ Accuracy

- Accuracy is the closeness with which an instrument reading approaches the true value of the quantity being measured

❖ Precision

- It is the measure of reproductability of the measurement or it is measure of degree of agreement with in a group of measurements.

❖ Sensitivity

- The ratio of magnitude of output signal to the magnitude of input signal.

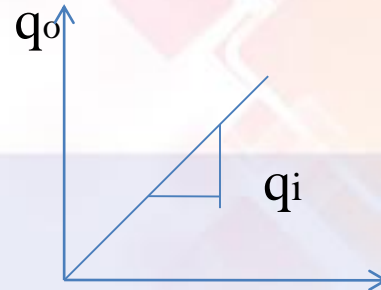

❖ Repeatability

• It is defined as the variation of scale reading and it is random in nature.

❖ Static error

- It is defined as difference between the measured value and the true value.
- $A = A_m - A_t$

❖ Dead Zone

- It is defined as the largest change in the input quantity for which there is no output in the instrument

❖ Dead Time

- Time required by the measurement system to begin to respond to changes in the input

❖ Threshold

- It is the minimum value below which no output change can be detected.

DYNAMIC CHARACTERISTICS OF TRANSDUCER

❖ Dynamic Characteristics are:

- Speed of Response.
- Measuring lag.
- Fidelity.
- Dynamic Error.

MATHEMATICAL MODEL OF TRANSDUCERS.

.

- It refers to the performance of the transducer when it is subjected to time varying input
- The number of parameter required to define the dynamic behavior of a transducer is decided by the order of transducer
- 1.Zero order transducer
- 2.First order transducer
- 3.Second order transducer
- 4.Higher order transducer

Zero order transducer.

The Input-Output relation of a Zero order transducer is given by:

$$y(t) = kr(t)$$

Where $r(t)$ is the I/P and $y(t)$ is the O/P Signal.

On applying Laplace transforms

$$Y(S) = KR(s)$$

$$\{Y(s) / R(s)\} = K$$

So we can say that:

1. Output varies exactly the same way as the input.
2. It represents the ideal dynamic performances

Example : Potentiometer.

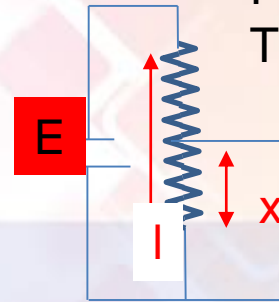

Fig:
POTENTIOME
TER

First Order Transducer

Input- Output Relation of a first order transducer is given by : **Therefore,**

$$a_1 \{dy(t)/dt\} + a_0 y(t) = b_0 u(t)$$

$$Y(s) / U(s) = K / (Ts + 1)$$

2 parameters k , T(tau) => First order.

Where a_0 and b_0 are parameters of the transducers.

On applying Laplace transforms: $K =$ Static sensitivity

$$a_1 s Y(s) + a_0 Y(s) = b_0 U(s)$$

$T =$ Time constant,

$$Y(s) [a_0 + a_1 s] = b_0 U(s)$$

$$Y(s)/U(s) = b_0 / (a_0 + a_1 s)$$

$$(b_0/a_0) / \{ 1 + (a_1/a_0)s \}$$

The order of a transducer is the highest derivative of the differential equation which describes the dynamic behavior of a transducer for a specific input

e.g $d^3 y(t)/dt^3 + d^2 y(t)/dt^2 + dy(t)/dt + 4y(t) = r(t)$

$Y(t) \rightarrow$ output

$R(t) \rightarrow$ input

Order $\rightarrow 3$

Highest derivatives $\rightarrow 3$

TEST INPUT

- Transducer are subjected to input which are random in nature
- The following test inputs are used to determine the dynamic behavior of the transducer
 - 1.Step input
 - 2.Ramp input
 - 3.Parabolic input
 - 4.Sinusoidal input



S.NO	NAME OF THE INPUT	TIME FUNCTION	LAPLAC E FUNCTI ON
1	Impulse Input	$R(t)=\delta(t)$ $=1$ for $t=0$ $=0$ for $\neq 0$	1
2	Step input	$r(t)=k$ for $t>0$ $=0$ for $t<0$ If $k=1$ $r(t)=u(t)=$ uni t step	K/S
3	Ramp input	$r(t)=kt$ for $t\geq 0$ $=0$ for $t<0$	K/S^2
4	Parabolic input	$r(t)=kt^2$ for $t\geq 0$ $=0$ for $t<0$	$2K/S^3$
	Sinusoidal input	$r(t)=k\sin\omega t$	$K/\omega S^2$

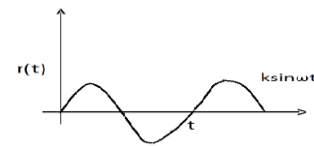
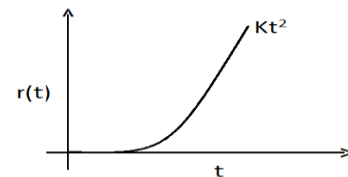
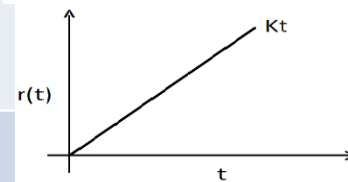
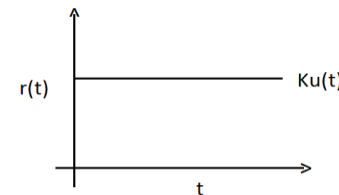
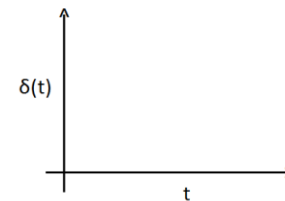

TYPES OF TRANSDUCERS

Classifications of Transducers

❖ Transducers can be classified as:

1. On the basis of transduction form used.
2. As primary and secondary transducers.
3. As passive and active transducers.
4. As analog and digital transducers.
5. As transducers and inverse transducers.

Temperature Transducer

- A **Temperature Transducer** is a device that converts the thermal quantity into any physical quantity such as mechanical energy, pressure and electrical signals etc. E.g. In Thermocouple the electrical potential difference is produced due to temperature difference across its terminals. So, thermocouple is an temperature transducer. Main **Features of Temperature Transducers**
- The input to them are always the thermal quantities
- They generally converts the thermal quantity into electrical quantity

Pressure Transducer

- **A pressure transducer is a device which converts an applied pressure into a measurable electrical signal.**
- A pressure transducer consists of two main parts, an elastic material which will deform when exposed to a pressurized medium and a electrical device which detects the deformation.
- The elastic material can be formed into many different shapes and sizes depending on the sensing principle and range of pressures to be measured.

Displacement Transducers

- The **linear variable differential transformer(LVDT)** (also called **linear variable displacement transformer**,^[1] **linear variable displacement transducer**,^[2] or simply **differential transformer**^[3]) is a type of electrical [transformer](#) used for measuring displacement (position). A counterpart to this device that is used for measuring rotary displacement is called a rotary variable differential transformer ([RVDT](#)).

Flow Transducers

- Flow transducers are used to measure air and liquid flow velocity. Flow transducers use different measuring principles. By means of the flow velocity, analysis units of flow transducers can calculate the flow level or determine the amount of flow with a counter. Our flow transducers operate based on ultrasound. A great advantage of this type of non-contact measurement is that sensors are not exposed to pressure surges or solid agents.

Unit 3-Resistive Transducers

POTENTIOMETER & LOADING EFFECT

Potentiometer & Loading Effect

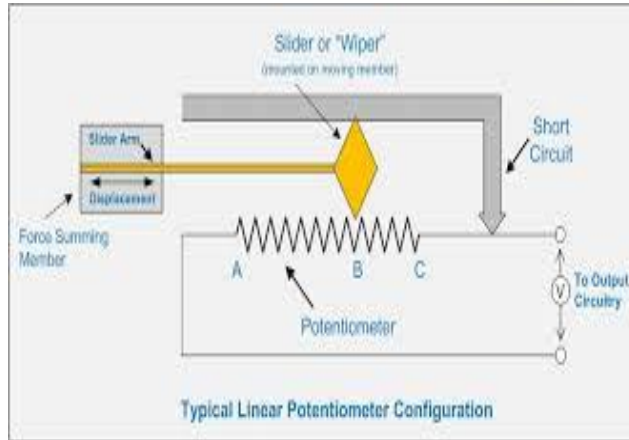

LINEAR POTENTIOMETER

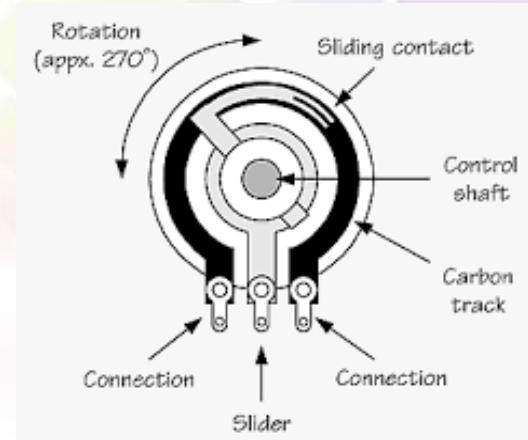

ROTARY POTENTIOMETER

Resistive Potentiometer

- A resistance potentiometer or a pot consist of resistive element provided with a sliding contact.
- The sliding contact is called a wiper.
- The motion of the sliding contact may be translatory or rotational.
- Some pot uses the combination of two motions i.e. translational as well as rotational.

Construction Of Potentiometer

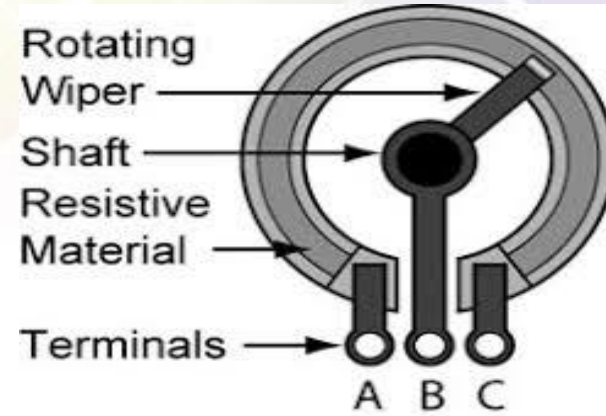
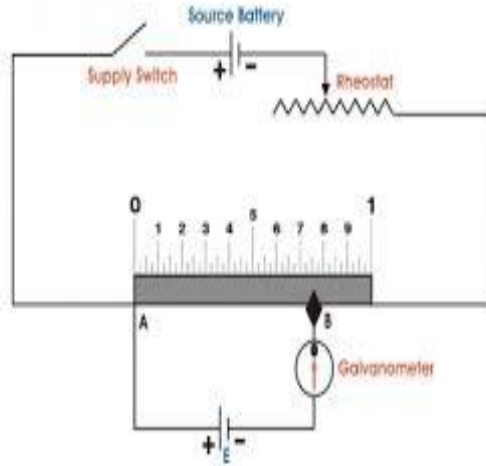

Loading Effect in Potentiometer

- The output of a potentiometric transducer is normally connected to an amplifier or a recorder or a meter which has a definite input impedance and hence a current will be drawn by this meter or recorder or amplifier.

LOADING EFFECT IN POTENTIOMETERS:-

The output of a potentiometric transducer is normally connected to an amplifier or a recorder or a meter which has a definite input impedance and hence a current will be drawn by this meter or recorder or amplifier.

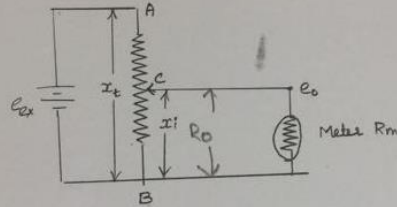

When a meter of input resistance R_m is connected across the potentiometer then the total resistance across points C and B is given by.

$$R_o = \frac{R_m R_p (x_i/x_t)}{R_m + R_p (x_i/x_t)}$$

$R_p \rightarrow$ Total potentiometric resistance

$R_m \rightarrow$ Meter resistance

$x_t \rightarrow$ Total length of travel of pot

$x_i \rightarrow$ Input displacement.

Let $\alpha \triangleq x_i/x_t$



SRM

UNIVERSITY

(Under section 3 of UGC Act 1956)



$$R_o = \frac{R_m R_p \alpha}{(R_m + R_p) \alpha} = R_{BC} \quad \text{--- (1)}$$

Output voltage across C and B

$$e_o = \frac{e_{ex} R_o}{(1-\alpha) R_p + R_o} \quad e_o = e_{ex} \frac{R_{BC}}{R_{BC} + R_{AC}} \quad \text{--- (2)}$$

where $R_{AC} = (1-\alpha) R_p$

On substituting equation (1) in (2)

$$e_o = e_{ex} \frac{\left(\frac{R_m R_p \alpha}{R_m + R_p \alpha} \right)}{(1-\alpha) R_p + \left(\frac{R_m R_p \alpha}{R_m + R_p \alpha} \right)}$$
$$= e_{ex} \frac{\left(\frac{R_m R_p \alpha}{R_m + R_p \alpha} \right)}{\frac{(R_m + R_p \alpha)(R_p - R_p \alpha) + R_m R_p \alpha}{R_m + R_p \alpha}}$$

$$= e_{ex} \frac{R_m R_p \alpha}{R_m R_p - \cancel{R_m R_p \alpha} + R_p^2 \alpha - R_p^2 \alpha^2 + \cancel{R_m R_p \alpha}}$$

$$= e_{ex} \frac{R_m R_p \alpha}{R_m R_p + R_p^2 \alpha - R_p^2 \alpha^2}$$

Dividing by R_p

$$e_o = e_{ex} \frac{R_m \alpha}{R_m + R_p \alpha - R_p \alpha^2}$$



Condition for with lead
Dividing by R_m

$$\frac{e_o}{e_x} = \frac{\alpha}{1 + \frac{R_p}{R_m} \alpha(1-\alpha)} \rightarrow (3)$$

Condition when there is no loading.

If $\frac{R_p}{R_m}$ becomes very small i.e. ≈ 0

then

$$\frac{e_o}{e_x} = \alpha = \frac{x_i}{x_t} \rightarrow (4)$$

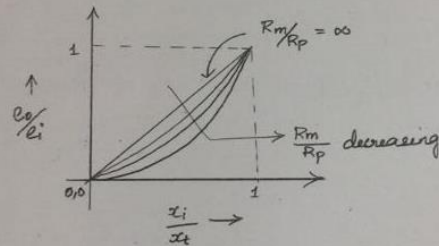

Equation (3) shows that there exists a non-linear relationship bet'n e_o and x_i

If $\frac{R_p}{R_m}$ ratio \uparrow , the nonlinearity goes on increasing.

Thus in order to keep linearity $\frac{R_p}{R_m}$ should be small. Or R_m should be as large as possible.



Error

Error = Output voltage under load -
Output voltage under no load

$$\begin{aligned} \text{Error} &= \frac{e_i \alpha}{\alpha(1-\alpha) \frac{R_p}{R_m} + 1} - e_i \alpha \\ &= -e_i \left[e_i \alpha - \frac{\alpha}{\alpha(1-\alpha) \frac{R_p}{R_m} + 1} \right] \\ &= -e_i \left[\frac{\alpha^2(1-\alpha) \frac{R_p}{R_m} + \alpha - \alpha}{\alpha(1-\alpha) \frac{R_p}{R_m} + 1} \right] \end{aligned}$$

Multiplying Nr and Dr by $\frac{R_m}{R_p}$

$$\text{Error} = -e_i \left[\frac{\alpha^2(1-\alpha)}{\alpha(1-\alpha) + \frac{R_m}{R_p}} \right]$$

$$\% e = -e_i \left[\frac{\alpha^2(1-\alpha)}{\alpha(1-\alpha) + \frac{R_m}{R_p}} \right] \times 100$$

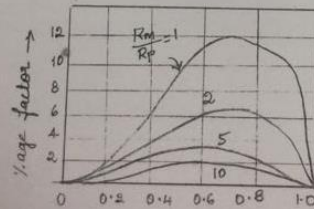

Variation of error due to loading effect due to potentiometer

$$\rightarrow K = \frac{\alpha_i}{\alpha_t}$$

Applications

- Calibration of voltmeter
- Calibration of ammeter
- Measurement of resistance

Advantages

- One of the advantages of the potential divider compared to a variable resistor in series with the source is that, while variable resistors have maximum resistance where some current will always flow.

STRAIN GAUGE

STRAIN GAUGE

- A strain gauge is a device used to measure strain on an object.
- As the object is deformed, the foil is deformed, causing its electrical resistance to change.
- This resistance change, usually measured using a Wheatstone bridge, is related to the strain by the quantity known as the *gauge factor*.

PRINCIPLE

- A strain gage (sometimes referred to as a Strain gauge) is a sensor whose resistance varies with applied force.
- It converts force, pressure, tension, weight, etc., into a change in electrical resistance which can then be measured.

Types of Strain Gauge

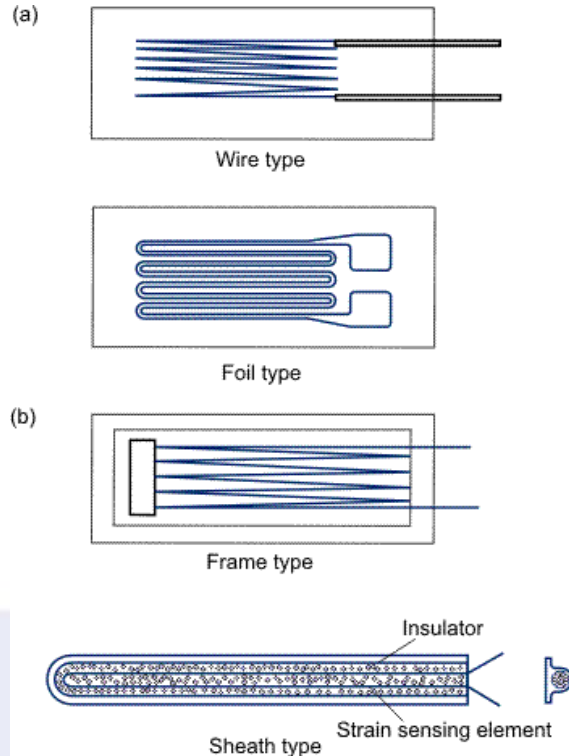

- Bonded and unbonded metal type.
- Wire type.
- Foil type.
- Frame type.
- Sheath type.

Bonded type strain gauge

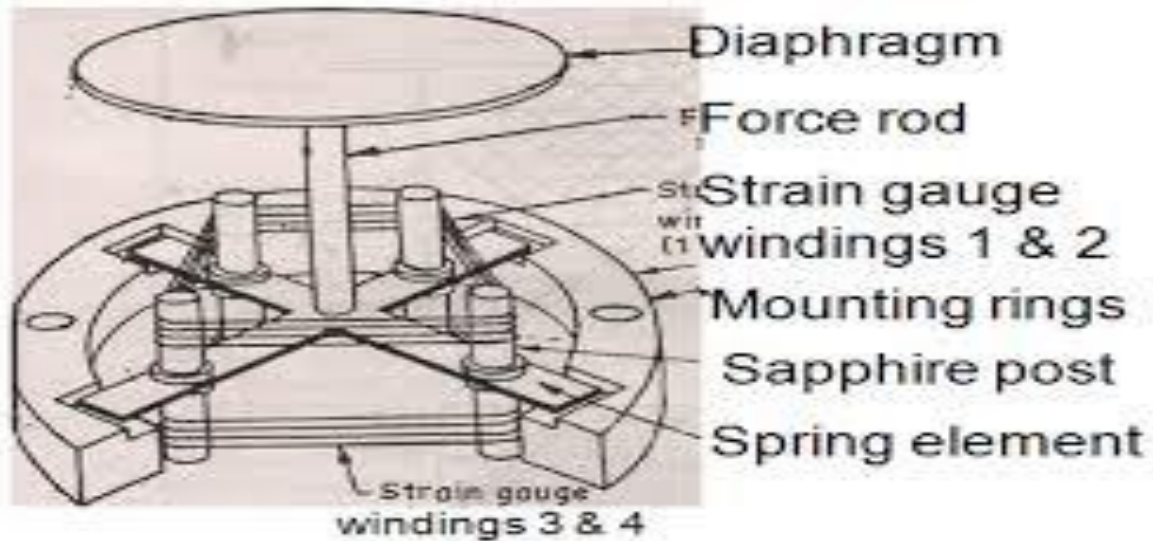
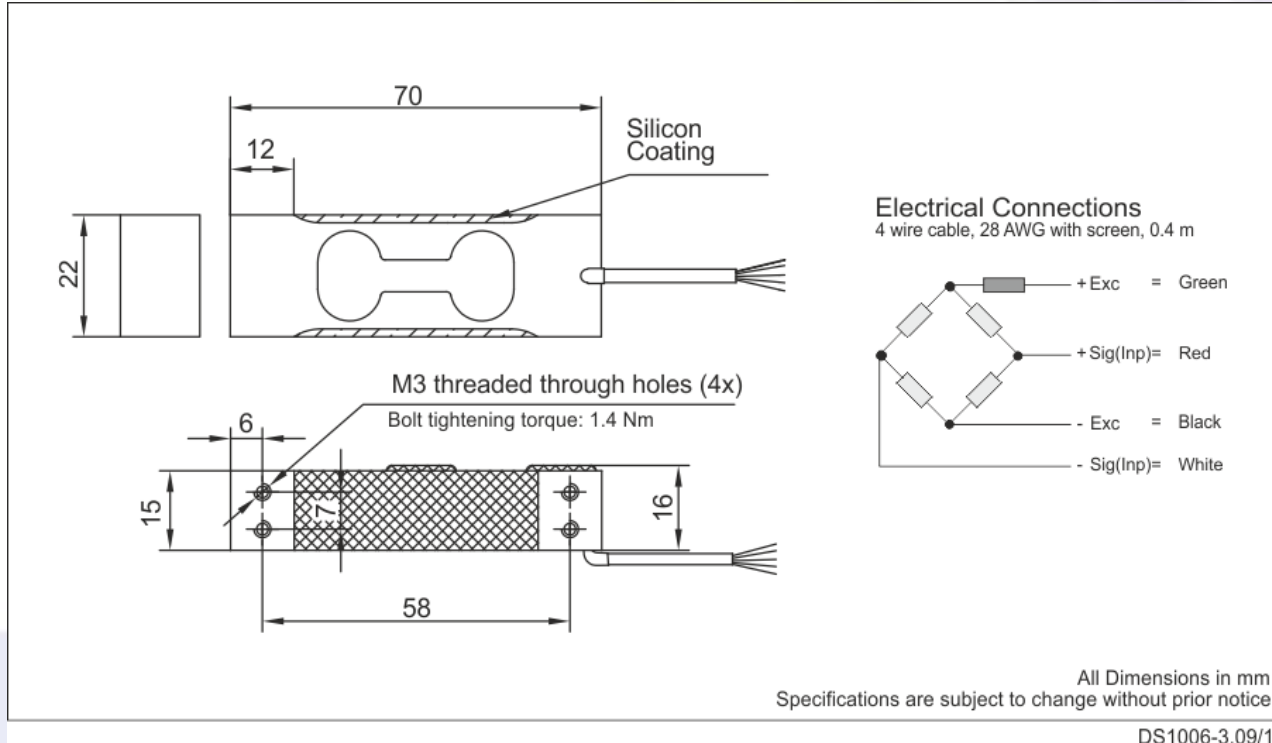

Fig. 2

LOAD CELL

PRINCIPLE

- A load cell is a transducer that is used to create an electrical signal whose magnitude is directly proportional to the force being measured.
- A load cell usually consists of four strain gauges in a Wheatstone bridge. The change in resistance of the strain gauge can be utilized to measure strain accurately when connected to an appropriate measuring circuit configuration. The electrical signal output is typically very small in the order of a few millivolts. It is amplified by an instrumentation amplifier before sending it to the measurement system.



ADVANTAGES

- Rugged and compact construction
- No moving parts
- Can be used for static and dynamic loading
- Highly Accurate
- Wide range of measurement
- Can be used for static and dynamic loading

DISADVANTAGES

- Mounting is difficult.
- Calibration is a tedious procedure.
- It cannot be used for the pressure measurement of highly reactive or corrosive materials because they can damage the gauge.
- It requires continuous electric energy for the production and display of signals.
- It cannot be used for the measurement of very high pressure if the diaphragm use is of plastic

APPLICATIONS

- BOLT FASTENING

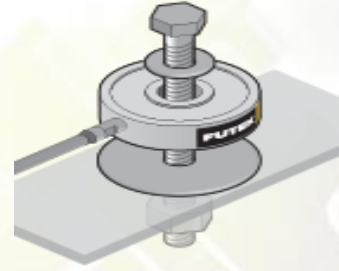

- CATHETER FORCE MEASUREMENT

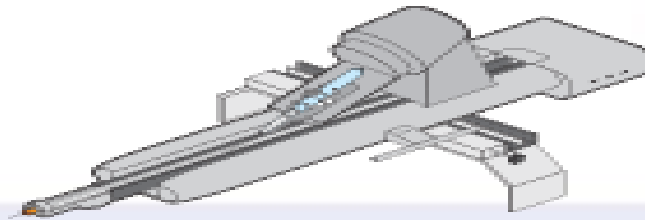

APPLICATIONS

- DNA SYNTHESIS

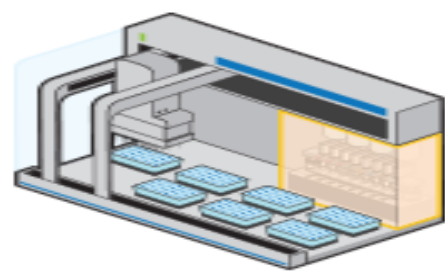

- COPTER PEDAL TESTING

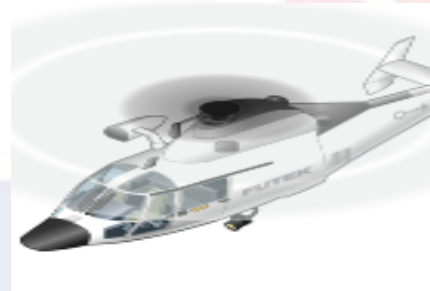

Proving Ring

PROVING RING:

- The proving ring is a device used to measure force. It consists of an elastic ring of known diameter with a measuring device located in the center of the ring.
- The proving ring is a device used to measure force. It consists of an elastic ring of known diameter with a measuring device located in the center of the ring.
- Proving rings can be designed to measure either compression or tension forces. Some are designed to measure both.

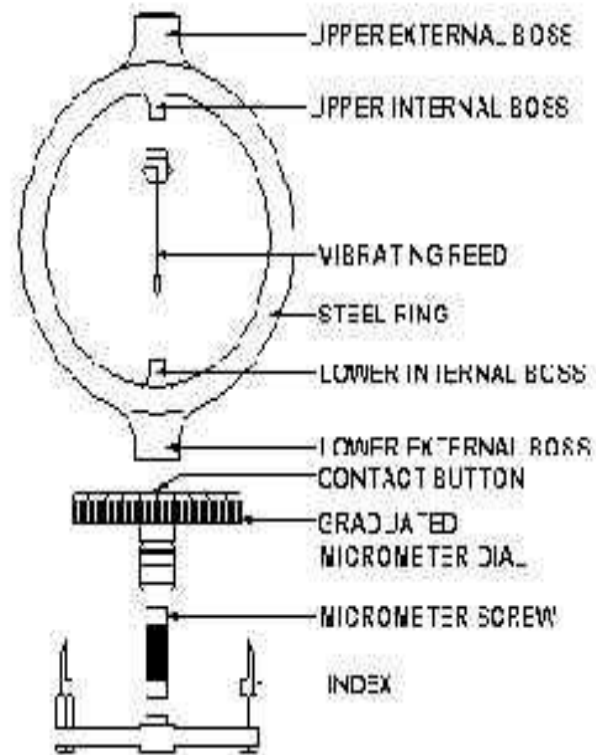

- The basic operation of the proving ring in tension is the same as in compression. However, tension rings are provided with threaded bosses and supplied with pulling rods which are screwed onto the bosses.
- Proving rings can be designed to measure either compression or tension forces. Some are designed to measure both. The basic operation of the proving ring in tension is the same as in compression. However, tension rings are provided with threaded bosses and supplied with pulling rods which are screwed onto the bosses.

APPLICATIONS

- Proving-ring technology is used to measure thermally induced displacements in large boreholes in rock
- Proving ring is used to measure force with its elastic ring of known diameter

MERITS AND DEMERITS

- MERITS –
 - It is easy to handle
 - It gives accurate values
 - Can be used in all condition
- DEMERITS –
 - It gives a zero error
 - Parallel axes error may occur

RESISTANCE TEMPERATURE DETECTOR

Working principle-

- A resistance temperature detector (RTD) can also be called a resistance thermometer as the temperature measurement will be a measure of the output resistance.
- Resistance temperature detectors (RTDs), are sensors used to measure temperature
- The main principle of operation of an RTD is that when the temperature of an object increases or decreases, the resistance also increases or decreases proportionally.

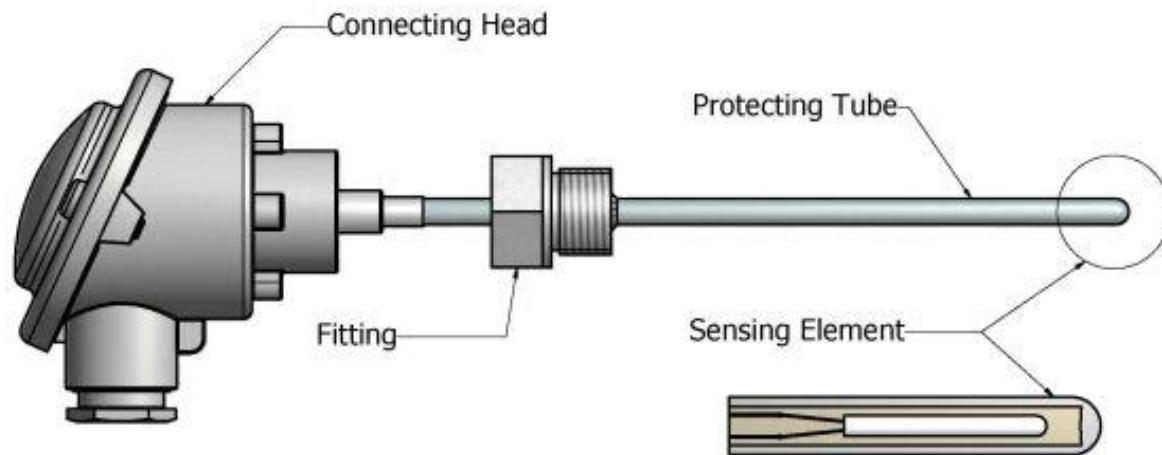

Applications-

- Air conditioning and refrigeration servicing
- Food Processing
- Stoves and grills
- Textile production
- Plastics processing
- Petrochemical processing
- Micro electronics
- Air, gas and liquid temperature measurement
- Exhaust gas temperature measurement

Advantages-

- Very stable output
- Linear and predictable
- Easy to verify and recalibrate
- High accuracy
- No special wire required for installation

Disadvantages-

- More limited temperature range (-200 deg C to 500 deg C)
- High initial price
- Slower response time than a thermocouple

THERMISTOR

PRINCIPLE

- A thermistor is a type of resistor whose resistance strongly depends on temperature. The word thermistor is a combination of word 'thermal' and 'resistor'

Thermistor



Advantages

- 1. High sensitivity
- 2. Can be used at normal room temperature.
- 3. Measurements upto high temperatures.
- 4. Small in size
- 5. Low cost

Disadvantages

- 1.High sensitivity allows the thermistor to work at low temperature range.
- 2.Need to be sterilized
- 3.Require form of power like batteries.

Applications

- Applications include temperature measurements , compensation and control.
- Used In detection of fire alarms.

GYROSCOPE

Gyroscope

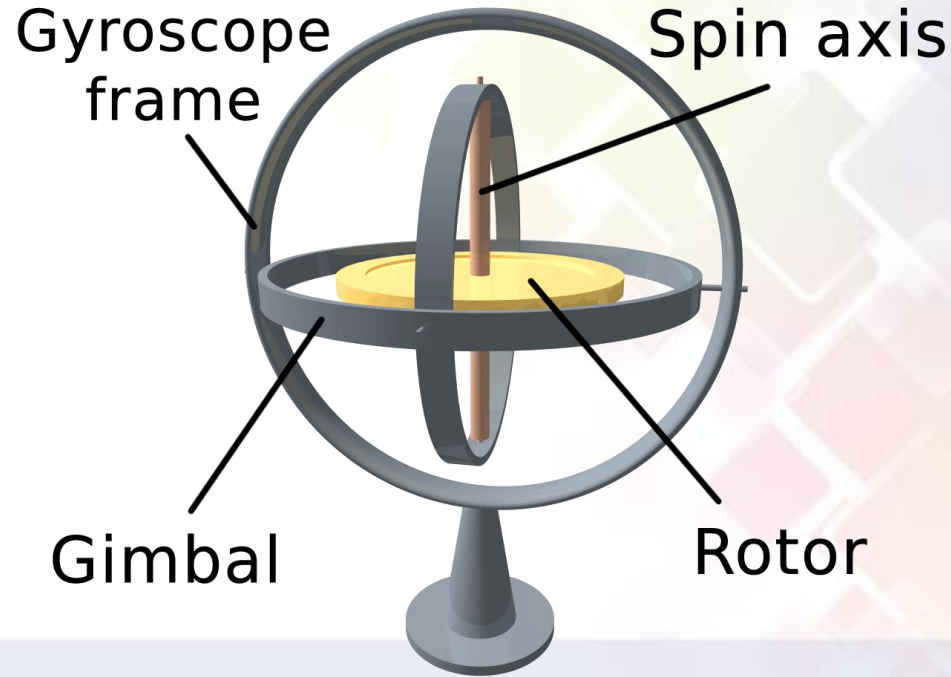

Principle

- A **gyroscope** is a spinning wheel or disc in which the axis of rotation is free to assume any orientation by itself. When rotating, the orientation of this axis is unaffected by tilting or rotation of the mounting, according to the [conservation of angular momentum](#). Because of this, gyroscopes are useful for measuring or maintaining orientation.

Working

- Gyroscope works on the principle that Angular momentum changes in the direction of Torque.

- $M = \text{mass of flywheel}$
 $W = Mg$
 $N = W = Mg$

while flywheel is rotating with angular velocity ω_s , in anticlockwise direction.

Now the torque due to weight of flywheel is in positive y direction.

Since angular momentum goes in the direction of torque so flywheel will go to y axis changing direction of L_s from x axis to y axis.

$$\text{so, } dL_s = I\omega \, dt$$

dt

Where dL_s/dt is torque by weight of flywheel.

We can now find the angular frequency of pivot Ω .

$$\Omega L_s = I\omega \quad (\text{balancing torques})$$

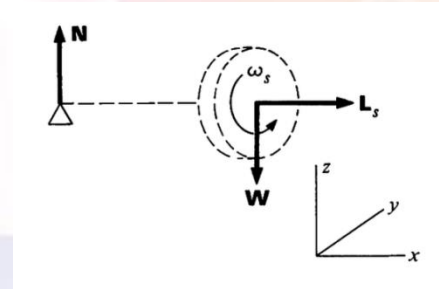

- We get

$$\Omega = \frac{lW}{I_s \omega_s}$$

- where I_s is moment of inertia of flywheel.
That is the reason why rotating gyroscope does not behave like pendulum when it is in normal gravitational field.
Same concept will be applied when flywheel moves in clockwise direction; now flywheel will move in **negative y** direction, as angular momentum points toward pivot.

Advantages and Disadvantages of Gyroscope

ADVANTAGES :

1. They really make smaller stabilized system.
2. They impart greater Stabilization.
3. They are Accurate and Easy to understand.

DISADVANTAGES :

1. The Gyroscopes are really expensive, but not in the terms of camera stabilization.
2. They are noisy if you are concerned about sound.
3. Pan and tilt speed is limited.
4. They take too much time to get up the speed.
5. They require another cable, battery and an inverter to work.

Application of Gyroscope

1. Coriolis Force Gyros
2. Lateral movement induced by rotation.
3. Torsional Resonator
4. Miniature Gyroscope in a chip
5. Wine glass Gyroscope
6. Conservation of momentum- Basic Gyroscope and Basic Rate Gyroscope.
7. Centripetal Force- Accelerator used for Rotation Sensing.

HOT WIRE ANEMOMETER

HOT WIRE ANEMOMETER

- It is used for measurement of velocity of flow
- Resistance wire is used as basic sensor which heated initially by passing an electric current
- These resistance wire are mounted on probe is cooled because of fanning effect
- The amount of cooling depends on the velocity variation how velocity

TYPE OF HOT WIRE ANEMOMETER

1.CONSTANT

TEMP TYPE (CCT)

- Principle:
 - Sensor resistance is kept constant by servo motor
- Advantages:
 - Easy to use
 - Accepted standard
- Disadvantages:
 - More complex circuit

2.CONSTANT CURRENT TYPE (CTT)

- Principle:
 - Current through sensor is kept constant
- Advantages:
 - High frequency response
- Disadvantage:
 - Difficult to use
 - Risk of probe burnout

CONSTANT CURRENT TYPE

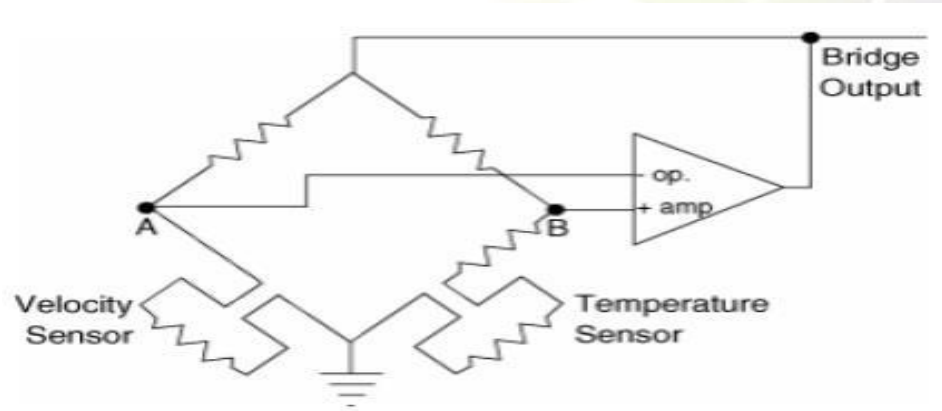

- > A fine resistance wire carries fixed current is exposed to the flow velocity.
- > The wire attains an equilibrium temp when I^2r heat generated in it is just balanced by the convective heat loss from its surface and it is essentially constant
- > Therefore the wire temp must adjust itself to change the convective heat until equilibrium is reached
- > This wire temp is measure of the flow velocity which is measured in terms of electrical resistance

CONSTANT TEMPERATURE TYPE

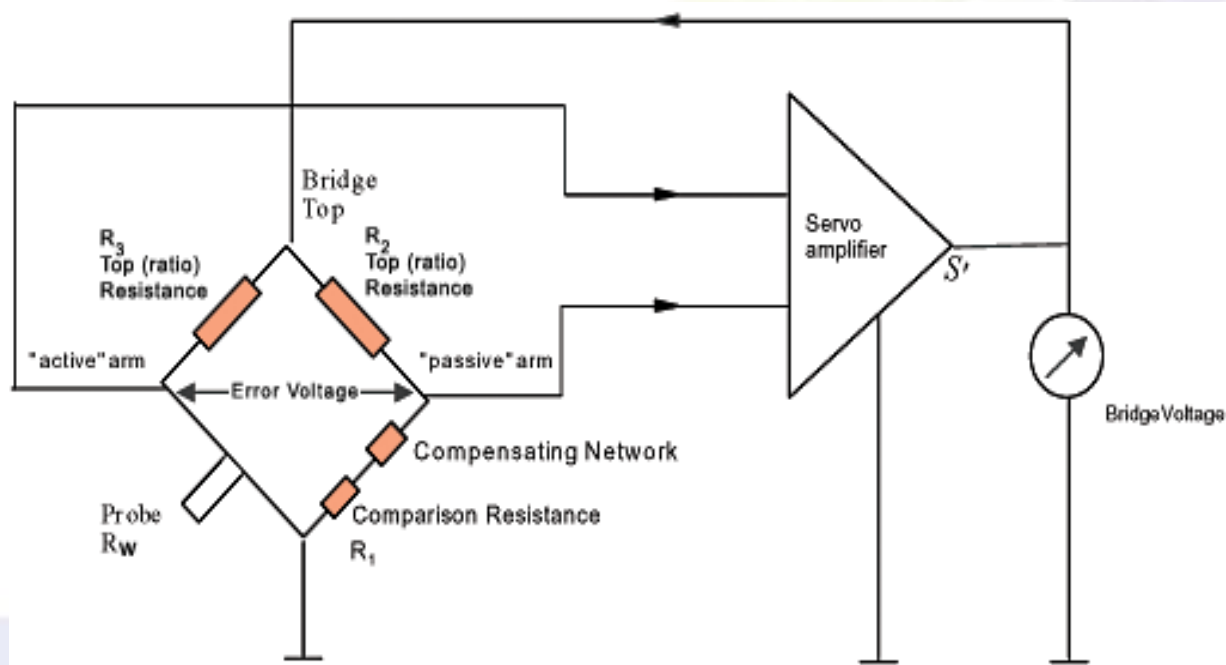

Figure 2. Principal diagram of Constant Temperature Anemometer.

- Current through the wire is adjusted to keep the wire temp constant .the current required to keep temp constant is a measure of the velocity
- It is most widely used method for measurement of velocity
 - Steady flow
 - It can only be used for steady flow not for large fluctuation in the velocity of flow
- Constant temp temp type circuit for fluctional
- It can be used for measuring both average and fluctuating component of velocity by balancing the bridge operation automatically
- With zeroflow velocity the bridge excuition is shut off ($i_w=0$),the hot wire assume the fluid temp

- R_3 is manually adjusted so that $R_3 > R_w$ to unbalance the bridge
- If excitation current is turned on unbalanced bridge produces an unbalanced voltage which is applied to high gain current amp
- So the current flow through R_w increases its temp thus its resistance R_w increases, E_e decreases .
- Since the amp has limited voltage so voltage cannot become zero
- Frequency response = 17000 cps (cycle per second)
- Average flow velocity = 9 m/s
 - 30000cps for 30 m/s
 - 50000cps for 90m/s

Unit 4-Inductive and Capacitive Transducers

SELF INDUCTIVE AND MUTUAL INDUCTIVE TRANSDUCER

SELF INDUCTIVE TRANSDUCER

1. What is self inductance?

Ans: Self inductance is the production of emf in a circuit when a magnetic flux linked with the circuit changes as a result of change of current.

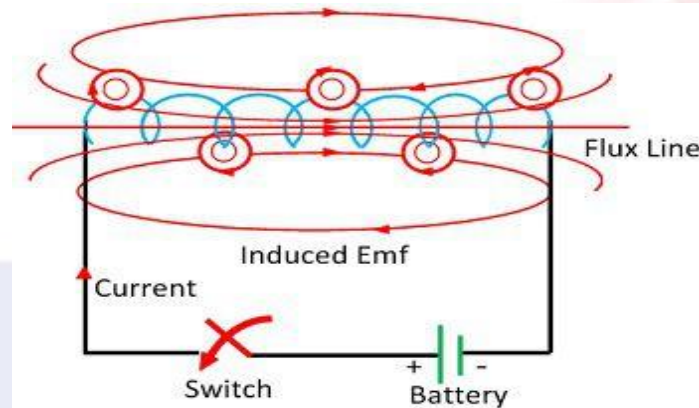

Self Inductance

- It works on principle of self inductance
- Only a single coil is employed.
- Self induction transducers are usually variable reluctance devices
- Application: this can be used as displacement sensor, proximity sensor etc.

MUTUAL INDUCTIVE TRANSDUCER

1. What is mutual inductance?

Ans: When an emf is induced in an coil because of change in current in a coupled coil, this effect is called as mutual inductance.

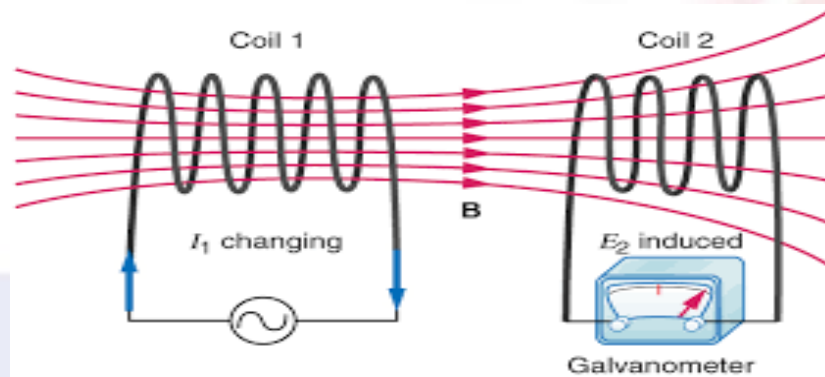

- A device specifically designed to produce the effect of mutual inductance between two or more coils is called a transformer.
- It works on principle of mutual inductance.
- Two or more number of coils are involved.
- Applications: LVDT ,transformer-step up and step down transformer.

INDUCTIVE TRANSDUCERS

- It is the most simple and most popular type of displacement transducer in which variation is achieved as function of displacement.
- Variation of inductance happens due to:
 - ❖ Change in number of turns
 - ❖ Change in reluctance
 - ❖ Change in permeability

APPLICATIONS

- Position Detection
- Speed Sensing
- Limit Switching
- Pulse Generation
- Distance Measurement

LINEAR VARIABLE DIFFERENTIAL TRANSFORMER

LVDT

The linear variable differential transformer is a type of electrical transformer used for measuring displacement. A counterpart to this device that is used for measuring rotatory displacement is called rotatory variable differential transformer.

WORKING PRINCIPLE:

LVDT works under the principle of mutual induction, and the displacement which is a non electrical energy is converted into an electrical energy. And the way how the energy is getting converted is described in working of LVDT in a detailed manner.

LVDT consists of a cylindrical former where it is surrounded by one primary winding in the centre of the former and the two secondary windings at the sides. The number of turns in both the secondary windings are equal, but they are opposite to each other, i.e., if the left secondary windings is in the clockwise direction, the right secondary windings will be in the anti-clockwise direction, hence the net output voltages will be the difference in voltages between the two secondary coil. The two secondary coil is represented as S1 and S2. Esteem iron core is placed in the centre of the cylindrical former which can move in to and fro motion

Case 1: On applying an external force which is the displacement, if the core remains in the null position itself without providing any movement then the voltage induced in both the secondary windings are equal which results in net output is equal to zero.

Case 2: They are used in applications where displacements ranging from fraction of mm to few cm are to be measured. The LVDT acting as a primary transducer converts the displacement to electrical signal directly.

Case 3: When an external force is applied and if the steel iron core moves in the right hand side direction then the emf induced in the secondary coil 2 is greater when compared to the emf voltage induced in the secondary coil 1.

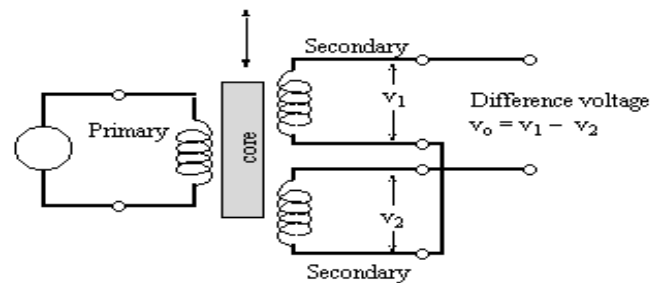
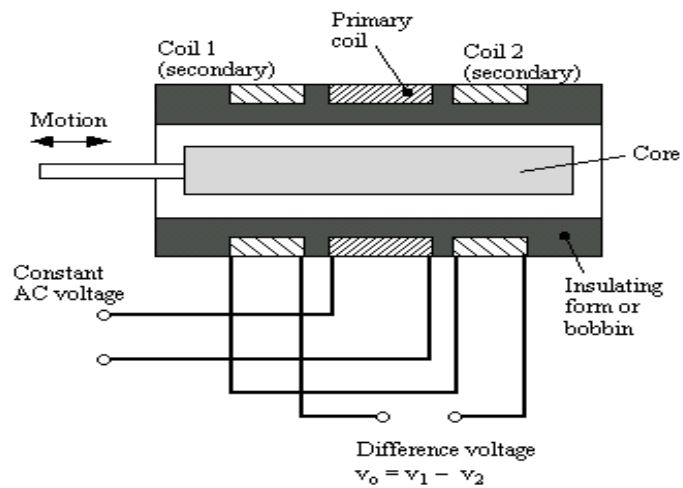

- Linear variable differential transducer circuit diagram

ADVANTAGES

1.High Range- The LVDT has a very high range for measurement of displacement. This can be used for measurement of displacement ranging from 1.25mm to 250mm.

2.There is no physical contact between the movable core and coil structure which means that LVDT is a frictionless device.

3.High input and High sensitivity-LVDT gives high input and many a time there is no need for amplification.

4.LVDT has low hysteresis and hence repeatability is excellent.

5.The fact that LVDT is a transformer means that there is complete isolation between excitation voltage given to the primary winding and the output produced by the secondary windings. This makes LVDT an effective analog computing

DISADVANTAGES

- 1.They are sensitive to a stray magnetic field.
- 2.Many a times transducer performance is affected by vibrations.
- 3.The temperature effects the performance of the transducer.

APPLICATIONS

1 They are used in applications where displacements ranging from fraction of mm to few cm are to be measured. The **LVDT** acting as a primary transducer converts the displacement to electrical signal directly.

2 They can also act as the secondary transducers. E.g. the Bourdon tube which acts as a primary transducer and convert pressure into linear displacement. then LVDT converts this displacement into electrical signal which after calibration gives the ideas of the pressure of fluid.

ROTARY VARIABLE DIFFERENTIAL TRANSFORMER (RVDT)

DEFINITION OF RVDT

- A variation of linear variable differential Transformer (LVDT) may be used to sense angular displacement This is the Rotary Variable Differential Transformer (RVDT).
- The circuit diagram of the RVDT is similar to the LVDT except that its core is in cam shaped and may be rotated.
- Most of the RVDT consist of wound , laminated stator and a salient two-pole rotor. The stator contains four slots which includes two secondary windings and both the primary windings

OPERATION

- The operation of RVDT is similar to that of LVDT. At the primary null position of the core. The output voltage of secondary winding S1 and S2 are equal and in opposition. Therefore, the net output is equal to zero. Any angular displacement from the null position will result in differential voltage output. The greater the angular displacement the greater will be the differential output. Hence the response of the transducer is linear.

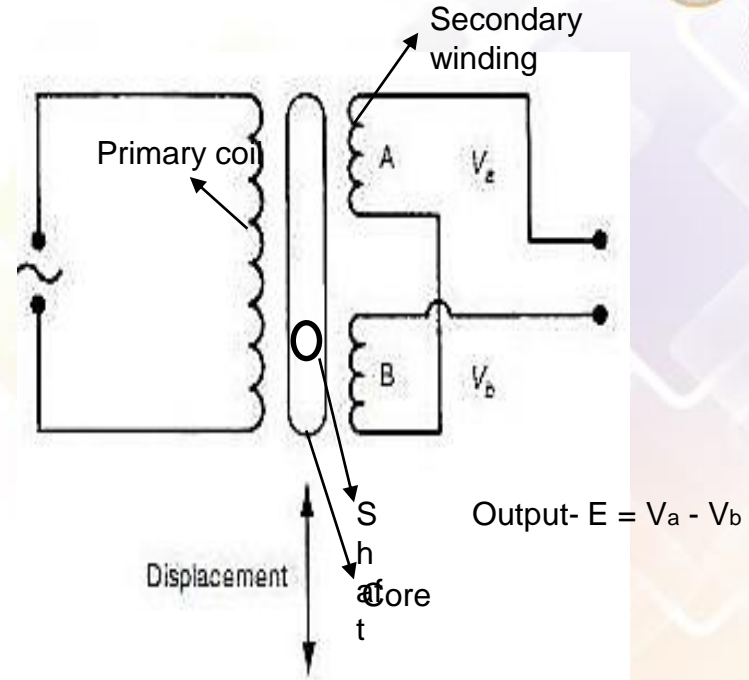

- Clockwise rotation produce the increasing voltage of secondary winding of one phase while counter clockwise rotation produce an increasing voltage of opposite phase.
- Hence, the amount of angular displacement and its direction may be ascertained from the magnitude and the phase of the output voltage of the transducer.
- The RVDT is one application that can measure the angle precisely within short distance.

ADVANTAGES OF RVDT

- Low sensitivity to temperature , primary voltages & frequency variations.
- Sturdiness.
- Low cost.
- Simple control electrons.
- Small size.

SYNCHROS AND MICROSYN

Synchros

- The term “synchro” is an abbreviation of the word “synchronous”.
- It is the name given to a variety of rotary, electromechanical, position-sensing devices.
- Synchro is an inductive device which works on the principle of rotating transformer.
- The term rotating transformer means the primary to secondary coupling can be changed by physically changing the relative orientation of the winding.
- So based on this working principle of synchro it can be used as POSITION TRANSDUCER.

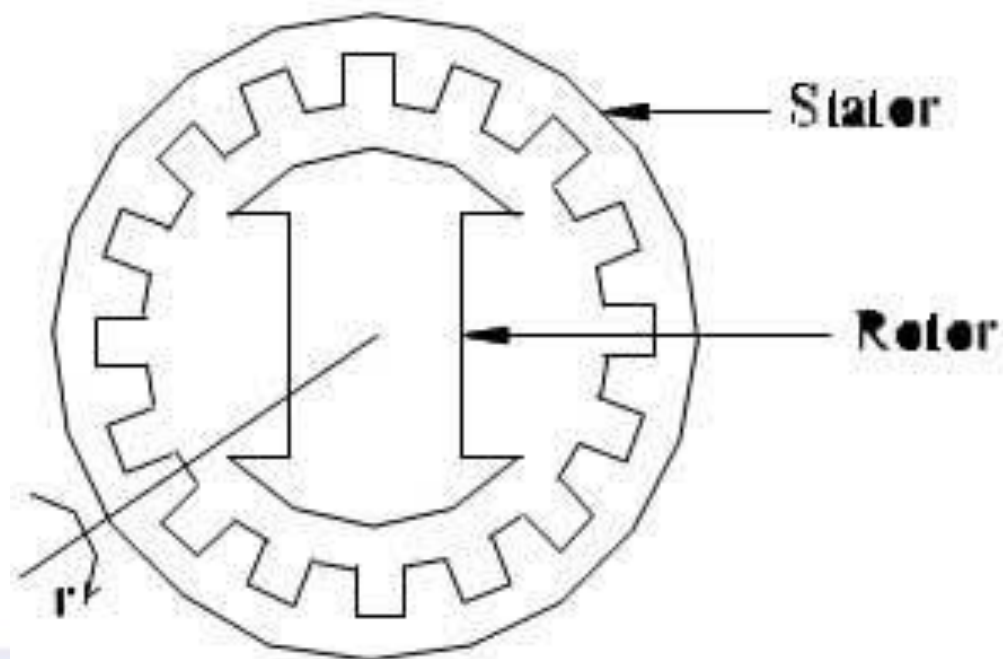

Excitation Voltage

- $e_r = E_r \sin \omega t$
- Induced emf = $K_t \cdot K_c \cdot E_r \sin \omega t$
- K_t = turn ratio
- K_c = coupling coefficient, it depends on rotor angular position.
- $e_{s1} = K_t \cdot K_1 \cdot \cos \theta \cdot \sin \omega t$
- $e_{s2} = K_t \cdot K_2 \cdot \cos(\theta + 120) E_r \sin \omega t$
- $e_{s3} = K_t \cdot K_1 \cdot \cos(\theta + 240) E_r \sin \omega t$
- $e_{s1s2} = \sqrt{3} \cdot K \cdot E_r \sin(\theta + 240) \sin \omega t$
- $e_{s2s3} = \sqrt{3} \cdot K \cdot E_r \sin(\theta + 120) \sin \omega t$
- $e_{s1s3} = \sqrt{3} \cdot K \cdot E_r \sin \theta \sin \omega t$

Applications

- Detection of winding length
- Position detection of stackers
- Angle detection : antenna bearing angles, and elevation angles
- Position detection of an automated carriage

Microsyn

- It is a variable reluctance transducer.
- It is most widely used in sensitive gyroscopic instruments
- At null position, voltage induced in coils 1 and 3 is balanced by those of 2 and 4.
- Motion of input shaft from null position increases reluctance of 1 and 3 and decreases that of 2 and 4.

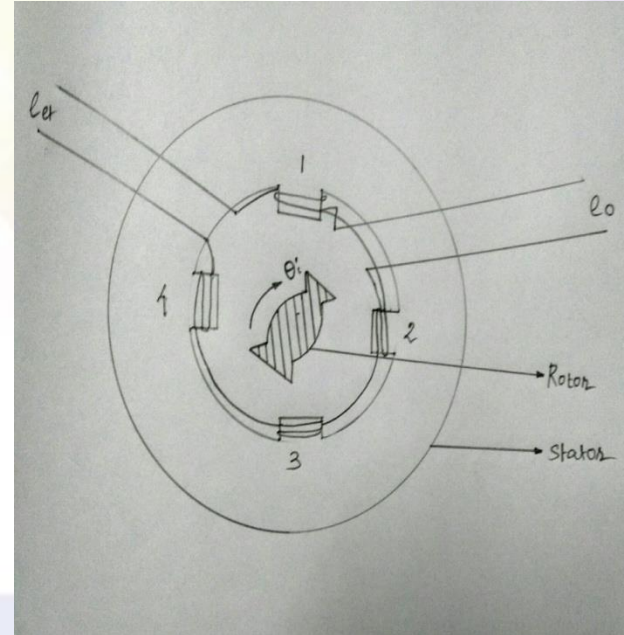

CAPACITIVE TRANSDUCER

CAPACITIVE TRANSDUCER

The principle of operation of capacitive transducers is based upon
The familiar equation for capacitance of a parallel plate capacitor.

$$\begin{aligned} \text{Capacitance } C &= \Sigma A/d \\ &= \Sigma_r \Sigma_o A/d \end{aligned}$$

Where ,

A=overlapping area of plates

d=distance between two plates

$\Sigma = \Sigma_r \Sigma_o$ =permittivity of medium

Types:

The capacitive transducer works on the principle of capacitance which may be caused by:

- Change in overlapping Area
- Change in the distance between the plates
- Change in dielectric constant

Uses of Transducers

- It can be used for measurement of both linear and angular displacement.
- It can be used for measurement of force and pressure.
- It can be used for measurement of humidity in gases.
- It is commonly used in conjunction with mechanical modifiers for measurement of volume , density , weight .

Change in overlapping Area

Examining the equation for capacitance it is found that the Capacitance is directly proportional to the area , of the plates . Thus the capacitance changes linearly with change in area of plates . Hence this type of capacitive transducer is useful for measurement of moderate to large displacement

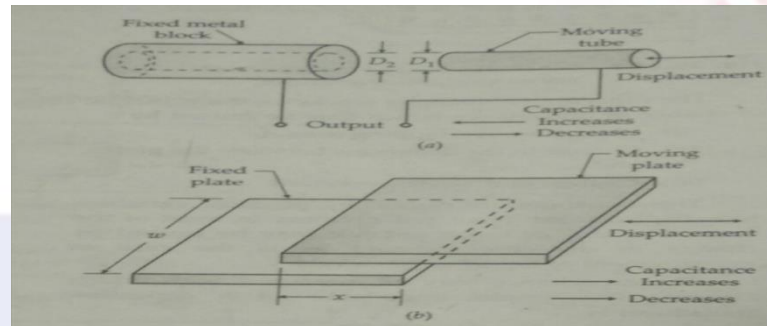

Change in the distance between the plates

Figure shows the basic form of a capacitive transducer utilizing the effect of change of capacitance with change in distance between the two plates . One is a fixed plate and the displacement to be measured is applied to the other plate which is movable . Since , the capacitance , varies inversely as the distance between the plates the response of this transducer is not linear . Thus , this transducer is useful only for measurement of extremely

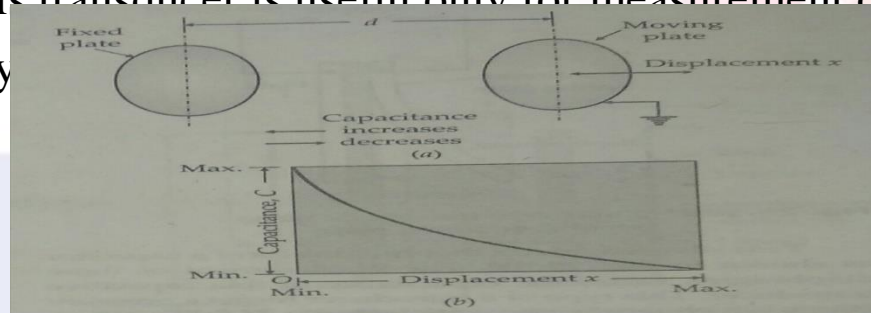

Change in dielectric constant

The third principle used in capacitive transducers is the variation of capacitance due to change in dielectric constant . Fig. shows a Capacitive transducer for measurement of linear displacement working on the above mentioned principle . These capacitive Transducer is normally used for measurement of liquid levels. Fig. shows a transducer used for water level measuring .

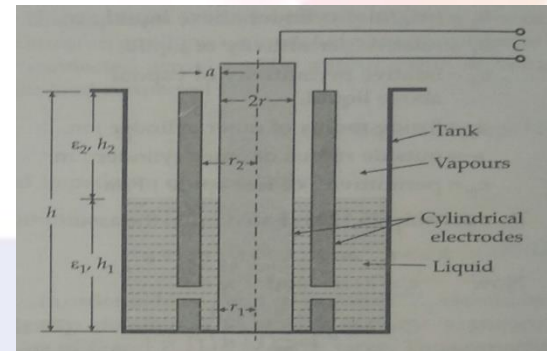
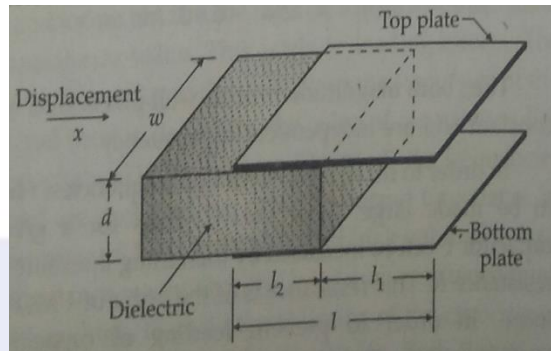

Advantages & Disadvantages

Advantages

- They require small force to operate & hence are very useful in small system.
- They are extremely sensitive.
- They have a good frequency response .
- They have a high input impedance and therefore the loading effects are minimum .
- A resolution of the order of 2.5×10^{-3} mm can be obtained with these transducers .

Disadvantages

- The capacitance of transducer may be changed on account of presence of materials like dust .
- The capacitive transducers are temperature sensitive .
- The instrumentation circuitry used with these transducers is very complex .
- The capacitive transducer show non-linear behaviour many a times on account of edge effects .
- The metallic parts of the transducer must be insulated from each other.

CAPACITOR MICROPHONE

Principle

- Capacitor microphone works on the principle as that of the capacitance transducer.
- It contains a movable diaphragm and a fixed plate
- When the sound waves hit the microphone, the diaphragm moves backwards and forwards.
- This changes the level of capacitance and as a result voltage changes are seen across the resistor connected.

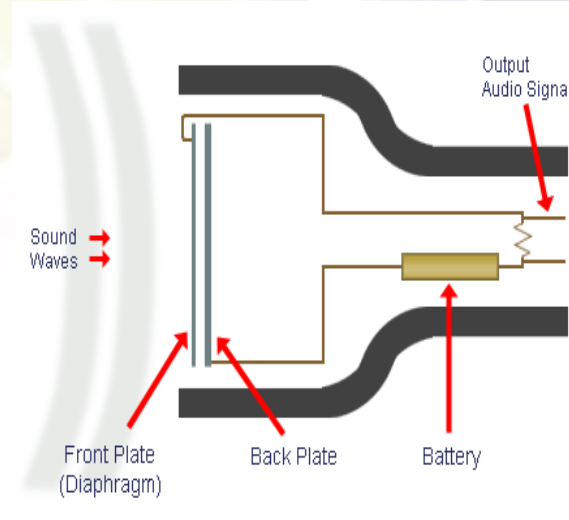

Applications

This condenser mic is a Behringer C-3. The interior illustrates that there is circuitry with this type of mic, thus the need for (phantom) power.

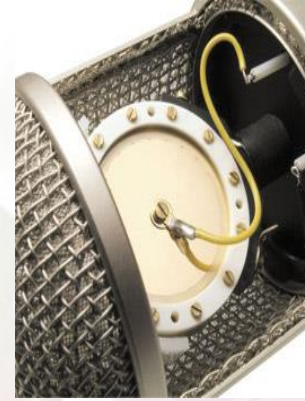
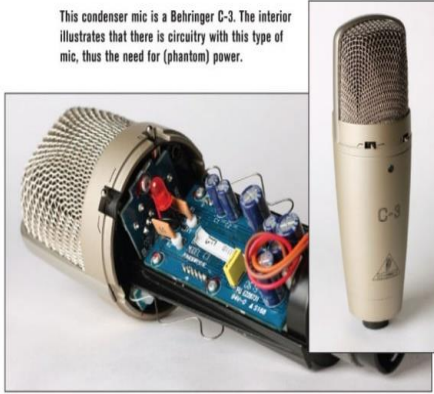

Advantages

- Typical output impedance is around 200 ohm or less.
- Frequency ranges from 20Hz to 20KHz and more.
- High quality sound recording.
- It is less robust.

Disadvantages

- High sensitivity, which causes overload due to loud noise.
- Internal construction is delicate.
- Sensitive to humid environment.
- They are damaged more easily than dynamic microphones

Unit 5-Miscellaneous Transducers

PIEZO ELECTRIC TRANSDUCER

What is Piezo Electric Effect?

Piezoelectric effect, is the ability of certain materials to generate an AC (alternating current) voltage when subjected to mechanical stress or vibration, or to vibrate when subjected to an AC voltage, or both.

The most common PiezoElectric material used is *Quartz*

WORKING PRINCIPLE

- The main principle of a piezoelectric transducer is that a force, when applied on the quartz crystal, produces **electric charges** on the crystal surface.
- Piezo electric transducer is also know to be mechanically stiff.
- Piezoelectric Transducer can measure **pressure** in the same way a **force** or an **acceleration** can be measured.

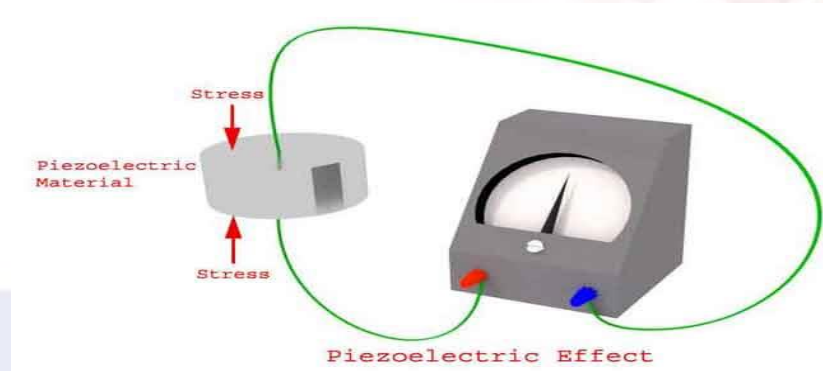

APPLICATIONS

- Due to its excellent frequency response, it is normally used as an accelerometer, where the output is in the order of (1-30) mV per gravity of acceleration.
- The device is usually designed for use as a pre-tensional bolt so that both **tensional and compression** force measurements can be made.
- Can be used for measuring force, pressure and **displacement** in terms of voltage

ADVANTAGES

- Very **high frequency** response.
- Self generating, so no need of external source.
- Simple to use as they have small dimensions and large measuring range.
- **Barium titanate and quartz** can be made in any desired shape and form. It also has a large dielectric constant. The crystal axis is selectable by orienting the direction of orientation.

DISADVANTAGES

- The piezoelectric transducer is used for **dynamic measurement** only.
- It has high temperature **sensitivity**.
- Some crystals are water soluble and get dissolve in high humid environment.

Hall effect Transducer

INTRODUCTION

- A Hall effect transducer is one that varies its output voltage in response to a magnetic field.
- Hall effect sensors are used for proximity switching, positioning, speed detection, and current sensing applications.
- In a hall-effect sensor a thin strip of metal has a current applied along it. In the presence of a magnetic field the electrons are deflected towards one edge of the metal strip, producing a voltage gradient across the short-side of the strip (perpendicular to the feed current).

- In its simplest form, the sensor operates as an analog transducer, directly returning a voltage. With a known magnetic field, its distance from the Hall plate can be determined. Using groups of sensors, the relative position of the magnet can be deduced.

WORKING PRINCIPLE

- When a beam of charged particles passes through a magnetic field, forces act on the particles and the beam is deflected from a straight path. The flow of electrons through a conductor is known as a beam of charged carriers.
- When a conductor is placed in a magnetic field perpendicular to the direction of the electrons, they will be deflected from a straight path. As a consequence, one plane of the conductor will become negatively charged and the opposite side will become positively charged. The voltage between these planes is called the Hall voltage.

Materials used commonly

- Gallium Arsenide
- Indium Arsenide
- Indium Phosphate
- Indium Antimonide
- Graphene

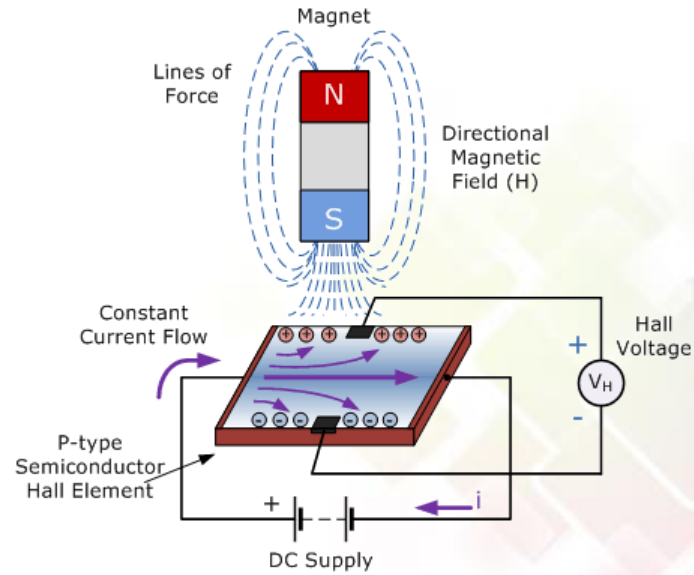

Hall effect sensor

Applications of hall effect transducer

- Position sensing
- Direct current transformer
- Automotive fuel level indicator
- Keyboard switch

Advantages

- A hall effect sensor may operate as an electronic switch which costs less than a mechanical switch and is much more reliable
- It can be operated up to 100kHz.
- It does not suffer from contact bounce because a solid state switch with hysteresis is used rather than a mechanical contact.
- It will not be easily affected by environmental contaminations, hence can be used under extreme conditions.
- Can measure a wide range of magnetic fields

Disadvantages

- Provides a much lower measuring accuracy than fluxgate magnetometers or magneto resistance based sensors. Moreover hall effect sensors drift significantly requiring compensation.
- Difficulty in operating under strong external magnetic fields
- low output drive capabilities
- An amplifier, voltage regulator, and output transistor is required to be integrated with to basic sensor to allow it to become a practical unit.

Proximity and Radiation Sensors

Working Principle

- A **proximity sensor** is a sensor able to detect the presence of nearby objects without any physical contact.
- Inductive Proximity Sensors detect magnetic loss due to eddy currents that are generated on a conductive surface by an external magnetic field. An AC magnetic field is generated on the detection coil, and changes in the impedance due to eddy currents generated on a metallic object are detected.
Other methods include Aluminum-detecting Sensors, which detect the phase component of the frequency, and All-metal Sensors, which use a working coil to detect only the changed component of the impedance. There are also Pulse-response Sensors, which generate an eddy current in pulses and detect the time change in the eddy current with the voltage induced in the coil.

The sensing object and Sensor form what appears to be a transformer-like relationship.

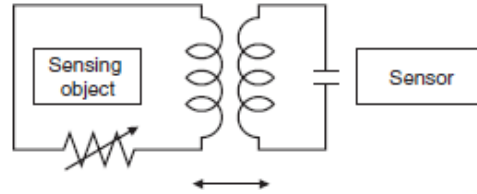

• Advantages

- It can detect both metal and non metal targets.
- Good stability
- High Speed
- Has low cost

Disadvantages

- It is affected by temperature and humidity
- There is a difficulty in designing
- Capacitive proximity sensors are not as accurate compare to inductive sensors.

Applications

- Parking sensors, systems mounted on car bumpers that sense distance to nearby cars for parking.
- Ground proximity warning system for aviation safety.
- Vibration measurements of rotating shafts in machinery
- Anti-aircraft warfare
- Roller coasters
- Conveyor systems
- Improvised Explosive Devices or IEDs
- Beverage and food can making lines.

- Mobile devices
 - Touch screens that come in close proximity to the face
 - Attenuating radio power in close proximity to the body, in order to reduce radiation exposure
 - 3D Touch will come true with the aid of proximity sensing elements.
- Automatic faucets.

Radiation Sensors

- Particle detectors, also called radiation detectors or sensors, are instruments designed for the detection and measurement of subatomic particles such as those emitted by radioactive materials, produced by particle accelerators or observed in cosmic rays.
- There are different type of detectors which are used :
 - 1.Geiger counter
 - 2.Scintillation detector
 - 3.Semiconductor detectors and etc.

Working Principle of Semiconductor detectors

- In semiconductor detectors, ionizing radiation is measured by the number of charge carriers set free in the detector material which is arranged between two electrodes, by the radiation. Ionizing radiation produces free electrons and holes. The number of electron-hole pairs is proportional to the energy of the radiation to the semiconductor. As a result, a number of electrons are transferred from the valence band to the conduction band, and an equal number of holes are created in the valence band.

Working Principle of Geiger counter

- The counter consists of a tube filled with an inert gas that becomes conductive of electricity when it is impacted by a high-energy particle. When a Geiger counter is exposed to ionizing radiation, the particles penetrate the tube and collide with the gas, releasing more electrons. Positive ions exit the tube and the negatively charged electrons become attracted to a high-voltage middle wire. When the number of electrons that build up around the wire reaches a threshold, it creates an electric current. This causes the temporary closing of a switch and generates an electric pulse that is registered on a meter, either acoustically as a click that increases in intensity as the ionizing radiation increases, or visually as the motion of a needle pointer.

Constructional Diagram

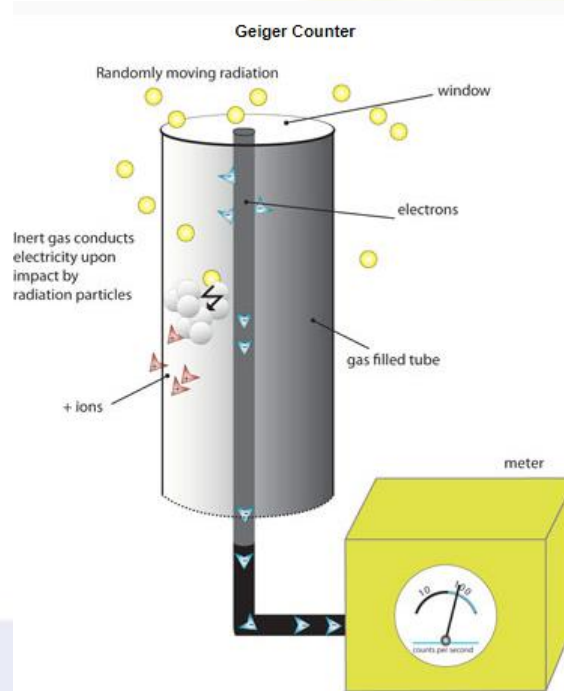

Advantages

- Advantages of semiconductor as a detecting medium is that they have much greater density than for a gas.
- Reduced ionisation energy.
- Geiger counters can can detect very low levels of radiation - a single particle can be detected.

Disadvantages

- the output pulse from a Geiger-Müller tube is always the same magnitude regardless of the energy of the incident radiation, the tube cannot differentiate between radiation types.
- Inability to measure high radiation rates due to the "dead time" of the tube.
- low detection efficiency for high-energy in semiconductor detectors.

SMART SENSOR

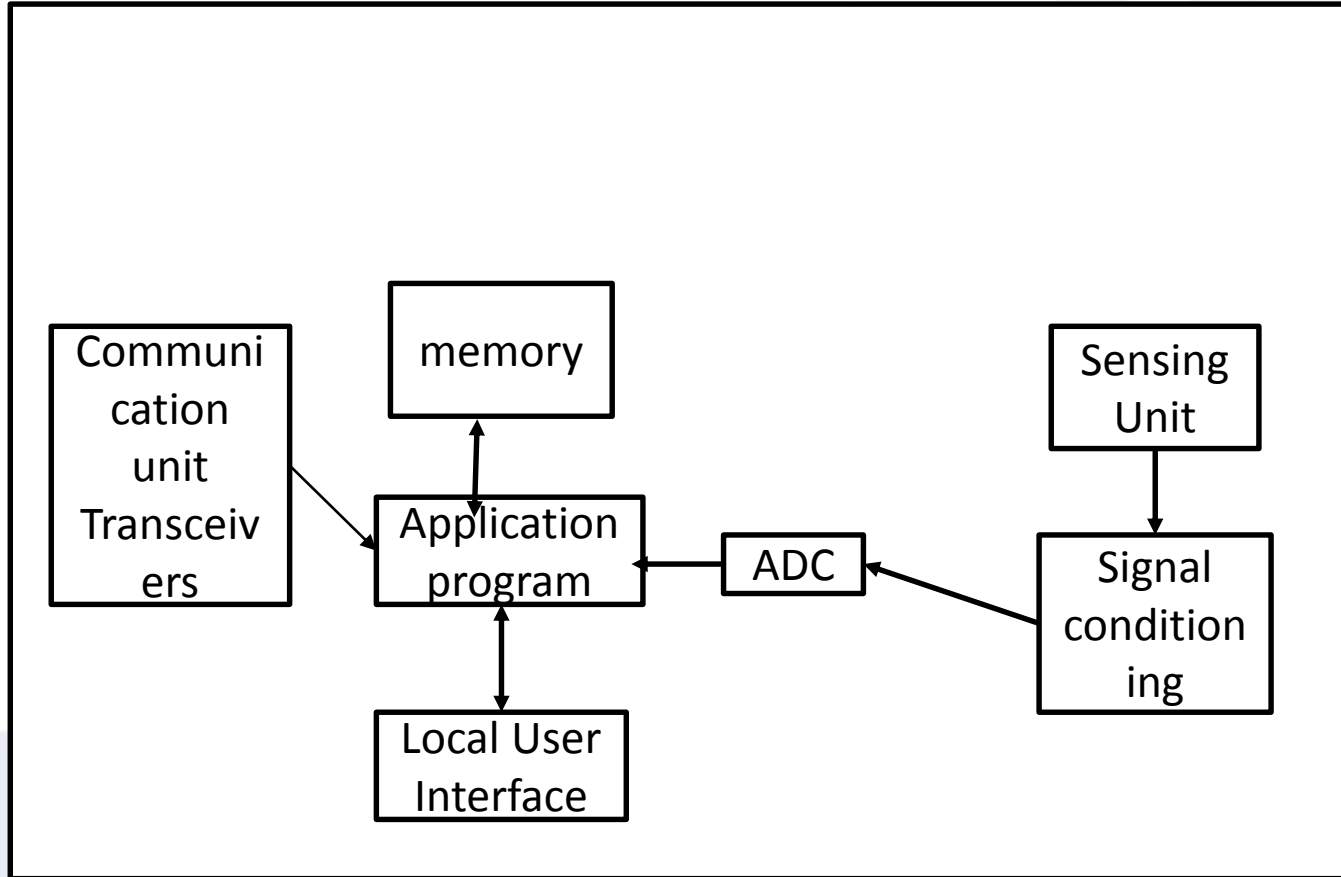

- A sensor node that combines the sensing and the computing abilities which are connected through the wireless communications. The network of such sensor nodes provides data as well as performing and controlling various tasks and functions.
- Sensors are used to monitor different parameters related to lighting conditions, noise levels, humidity, soil makeup, mechanical stress levels, presence or absence of certain types of objects and other properties.
- Structure of Smart Sensor

Application

1. Flood and water level monitoring system
2. Enviromental Monitoring system
3. Traffic Monitoring and controlling system
4. Energy savinf in atificial lighting
5. Remote system monitoring and equipment fault diagnostics
6. Industrial Application

FIBER OPTIC SENSOR

Fiber Optical technology have significantly changed the telecommunications industry. The ability of carry gigabits of data at the speed of the light increased the research potential in optical fiber. simultaneous improvements and cost reductions in optoelectronic components leds to similar emergence of new product area.

There are two type of fiber optic sensor which are

1. Pure fiber sensor
2. Remote optic sensors

Application of fiber optic sensor

Fiber optic sensors are used in several areas. Specifically

1. Measurement of physical properties such as strain, displacement, temperature, pressure and acceleration in structures of any shapes or size
2. Monitoring the physical health of structures in realtimes
3. Tunnels: Multipoint extensometers, convergence monitoring, shotcrete/
4. Prefabricated vaults evaluation and joints monitoring damage detections.
5. Buildings and Bridges: concrete monitoring during setting, crack monitoring, prestressing monitoring, spatial displacement monitoring, concrete-steel interaction, and post-seismic damages evaluation.

BIOSENSORS & FILM SENSORS



❑ BIOSENSORS

- ❖ Biosensors is an analytical device , the sensor which integrates the biological elements with the physiochemical transducer to produce an required electrical signal.

Types of biosensors:

- Electrochemical biosensors.
- Amperometric biosensors.
- Blood-glucose biosensor.
- Potentiometric biosensor.
- Conduct metric biosensors.

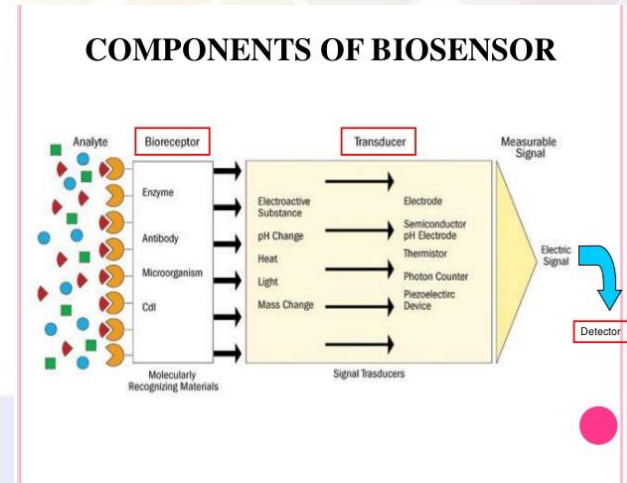

Advantages:

- Rapid and continuous measurement
- High specificity
- Very less usage of reagents required for calibration
- Fast response time

Disadvantages:

- Heat sterilization is not possible as this would denature the biological part of the biosensor.
- The membrane that separates the reactor media from the immobilized cells of the sensor can become fouled by deposits.



□ Film sensors

- Pro-Wave presents a series of mechno-electrical **sensors** and detectors produced by advanced piezoelectric polymer **film** technology. The polymer **film** of polyvinylidene fluoride (PVF2) exhibits a conspicuous piezoelectric effect and also has high compliance comparing with other piezoelectric crystals or ceramic materials.

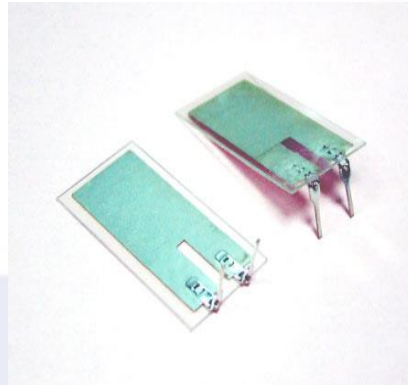

FEATURES:

- High mechno-electrical efficiency in planar , thickness and hydrostatic modes.
- Low mechanical and acoustic impedance.
- High resistance to moisture.
- Plaint , flexible , tough.

APPLICATION:

- Vibration sensor and motion detectors.
- Low weight accelerometers.
- Pressure or force sensors.
- Keyboards , keypads and touch pads.

MEMS & NANO SENSOR , DIGITAL TRANSDUCER.

Microelectromechanical system is a technology of microscopic devices, particularly those with moving devices.

MEMS

INTRODUCTION

- It is made of up of components of the range of microscopic range.It became practical once they could be fabricated using modified semiconductors
- They also work in the nanometer scale as NEMS.
- At first it was based on silicocon alone.It is made of up of components of the range of microscopic range.It became practical once they could be fabricated using modified semiconductors
- Analog devices are nowadays built by the help of these mems.

- MEMS is actually a type of transducer.
- Advantages of MEMS devices include small size, light weight, low power consumption and high functionality compared to conventional devices.
- MEMS technology offers cost reduction due to batch processing techniques similar to semiconductor Integrated Circuit (IC) manufacturing.
- The market value for the MEMS industry is around \$11 billion.

APPLICATION OF MEMS

- It is used in mechanical domain such as Pressure sensors, Accelerometers, Gyroscopes and in Optical MEMs such as Micromirrors
- Its main application proved advantageous in the field of bio-medical instrumentation.
- In automotive system like Airbags, active suspension.
- Earthquake detection and Gas shutoff and shock and Tilt Sensing.

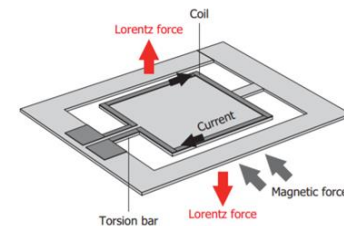
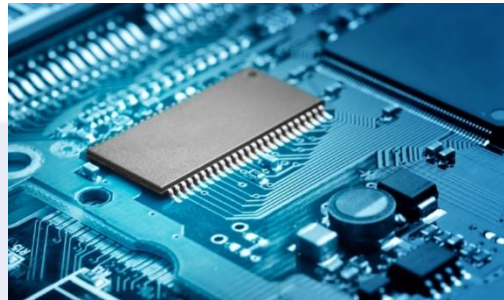

Advantages

- Very small size, mass, volume
- Very low power consumption
- Low cost
- Easy to integrate into systems or modify
- Small thermal constant
- Can be highly resistant to vibration, shock and radiation
- Batch fabricated in large arrays.
- Improved thermal expansion tolerance