

What is Endoscopy?

- **Endoscopy** is the examination and inspection of the interior of body organs, joints or cavities through an endoscope to allows physicians to peer through the body's passageways.
- An **Endoscope** is a device using fiber optics and powerful lens systems to provide lighting and visualization of the interior of a joint. The portion of the endoscope inserted into the body may be rigid or flexible, depending upon the medical procedure.

Endoscopy - Equipment

Endoscopy consist of a control head and a flexible shaft with a manoeuvrable tip.

The head is connected to a light source via an ‘umbilical’ cord, through which pass other tubes transmitting air, water and suction, etc.

The suction channel is used for the passage of diagnostic tools (e.g. biopsy forceps) and therapeutic devices.

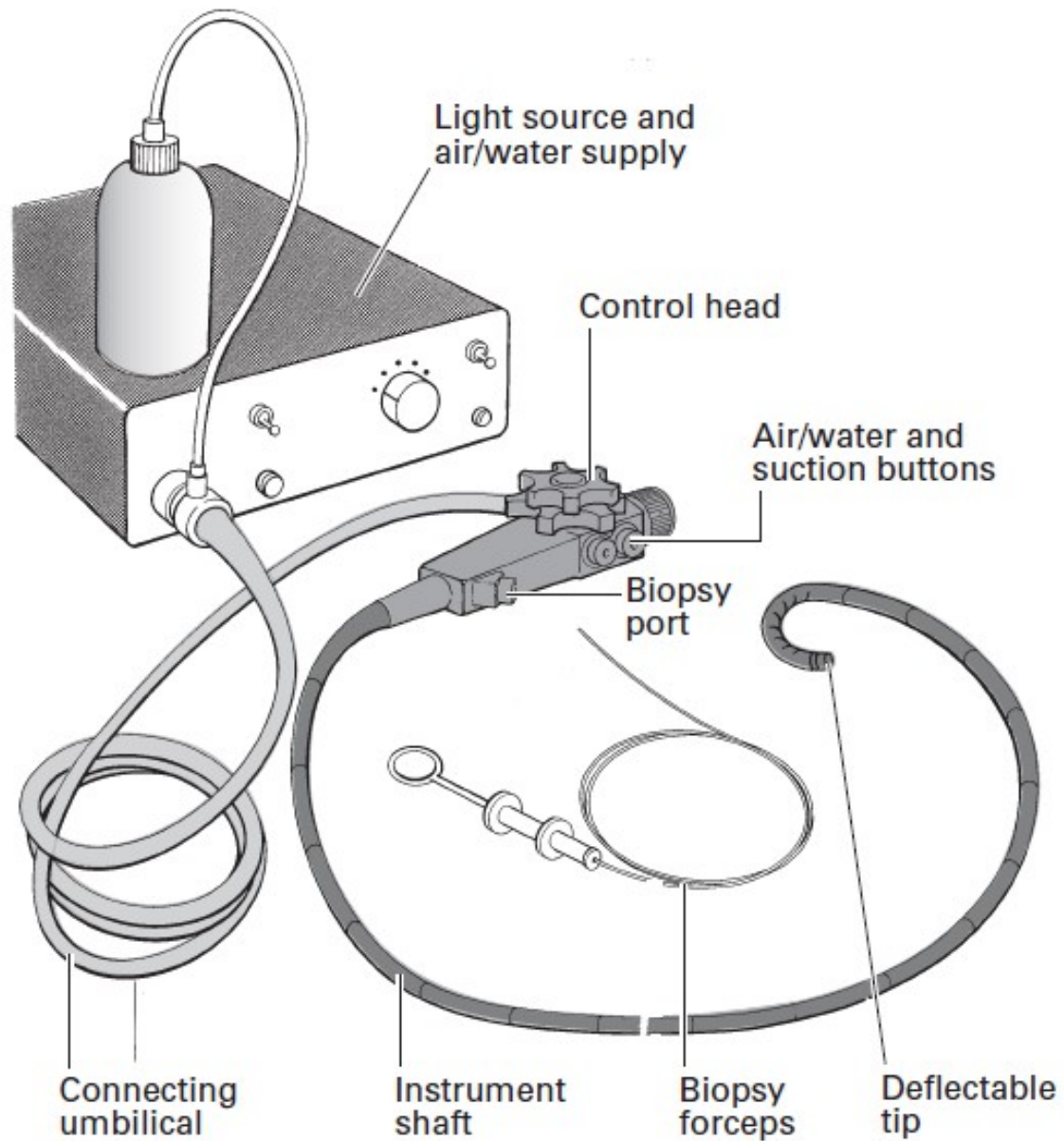

Fig. 1.1 Fibreoptic endoscope system.

Fibreoptic instruments

- These are based on optical viewing bundles, well described as a ‘highly flexible piece of illuminated spaghetti’.
- The viewing bundle of a standard fibre-endoscope is 2–3mm in diameter and contains 20000–40000 fine glass fibres, each close to 10 μ m in diameter.
- Light focused onto the face of each fibre is transmitted by repeated internal reflections (Fig.·1.2).
- Faithful transmission of an image depends upon the spatial orientation of the individual fibres being the same at both ends of the bundle (a ‘coherent’ bundle).
- Each individual glass fibre is coated with glass of a lower optical density to prevent leakage of light from within the fibre, since the coating does not transmit light. This coating and the space between the fibres causes a dark ‘packing fraction’, which is responsible for the fine mesh frequently apparent in the fibreoptic image (Fig.·1.3).
- For this reason, the image quality of a fibreoptic bundle, though excellent, can never equal that of a rigid lens system.

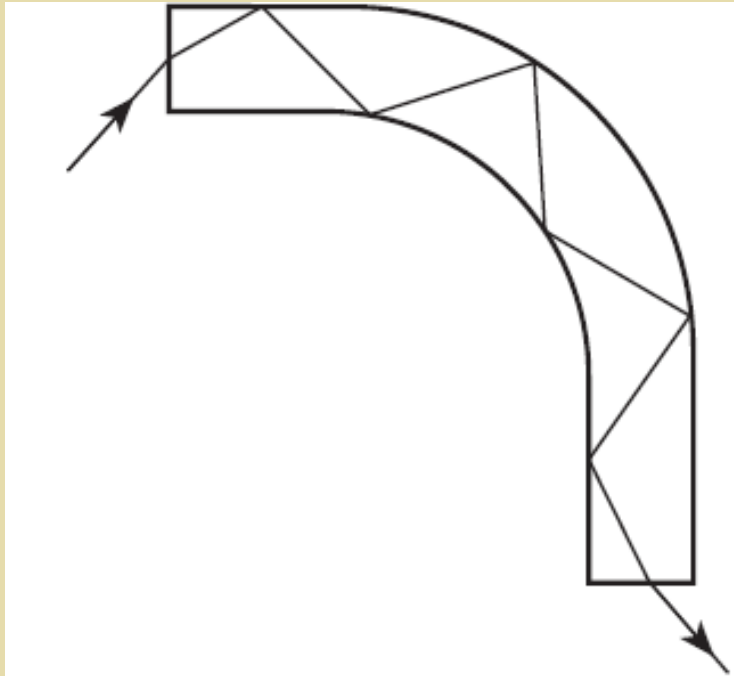

Fig. 1.2 Total internal reflection of light down a glass fibre.

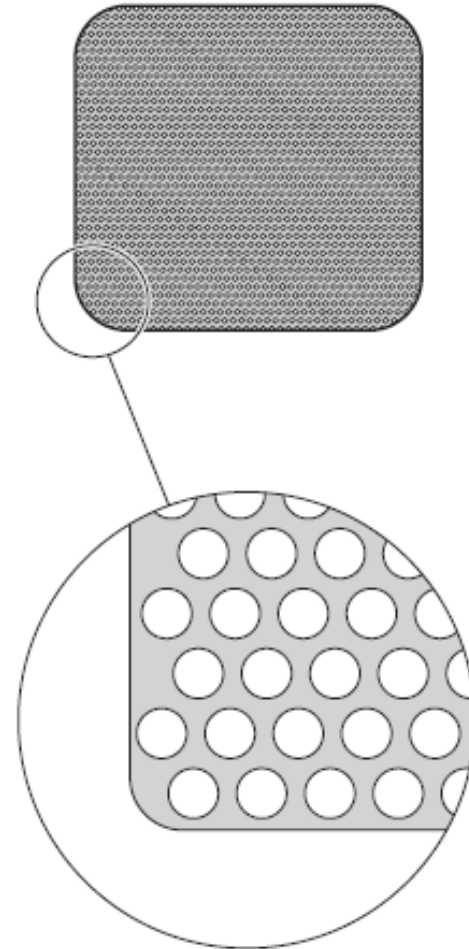

Fig. 1.3 Fibre bundle showing the 'packing fraction' or dead space between fibres.

- fibreoptic bundles are extremely flexible, and an image can be transmitted even when tied in a knot.
- In most modern instruments the distal lens which focuses the image onto the bundle is fixed, and a pin-hole aperture gives a depth of focus from 10–15cm down to about 3mm.
- The image reconstructed at the top of the bundle is transmitted to the eye via a focusing lens, adjustable to compensate for individual differences in refraction.

Video-endoscopes

These are mechanically similar to fibre-endoscopes, with a charged couple device (CCD) 'chip' and supporting electronics mounted at the tip, to and fro wiring replaces the optical bundle and further electronics and switches occupying the site of the ocular lens on the upper part of the control head.

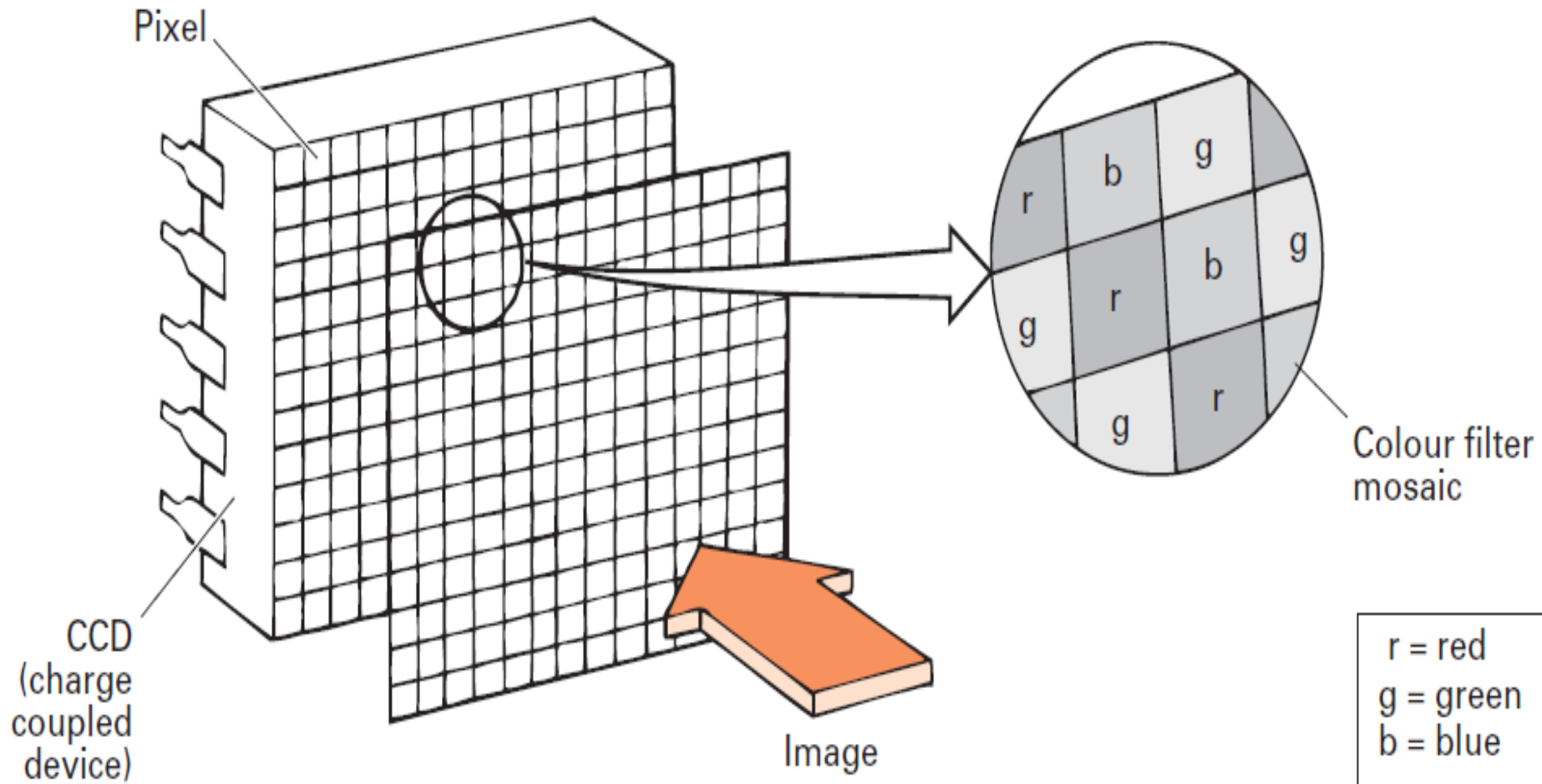

Fig. 1.4 Static red, green and blue filters in the 'colour' chip.

CCD chip

- CCD chip is an array of 33000–100000 individual photo cells (known as picture elements or pixels) receiving photons reflected back from the mucosal surface and producing electrons in proportion to the light received.
- In common with all other television systems the individual receptors of the CCD respond only to degrees of light and dark, and not to colour.
- ‘Colour’ CCDs have extra pixels to allow for an overlay of multiple primary colour filter stripes, making the pixels under a particular stripe respond only to light of that particular colour (Fig.·1.4).

CCD chip

- ‘Black and white’ (or, more correctly, sequential system) CCDs can be made smaller, or potentially of higher resolution, by the expedient of illuminating *all the pixels with intermittent* primary colour strobe-effect lighting produced by rotating a colour filter wheel within the light source (Fig. 1.5).
- The sequential primary colour images (in the gut mostly red, some green and little blue) are stored transiently in banks of memory chips in the processor and fed out sequentially to the red/blue/green electron guns of the TV monitor.
- The large numbers of chips and sophisticated computer ‘image-processing’ technology used to optimize the underlying single CCD output account for the excellence of the image produced by sequential CCD systems (and the high price involved), as well as the relatively large processor.

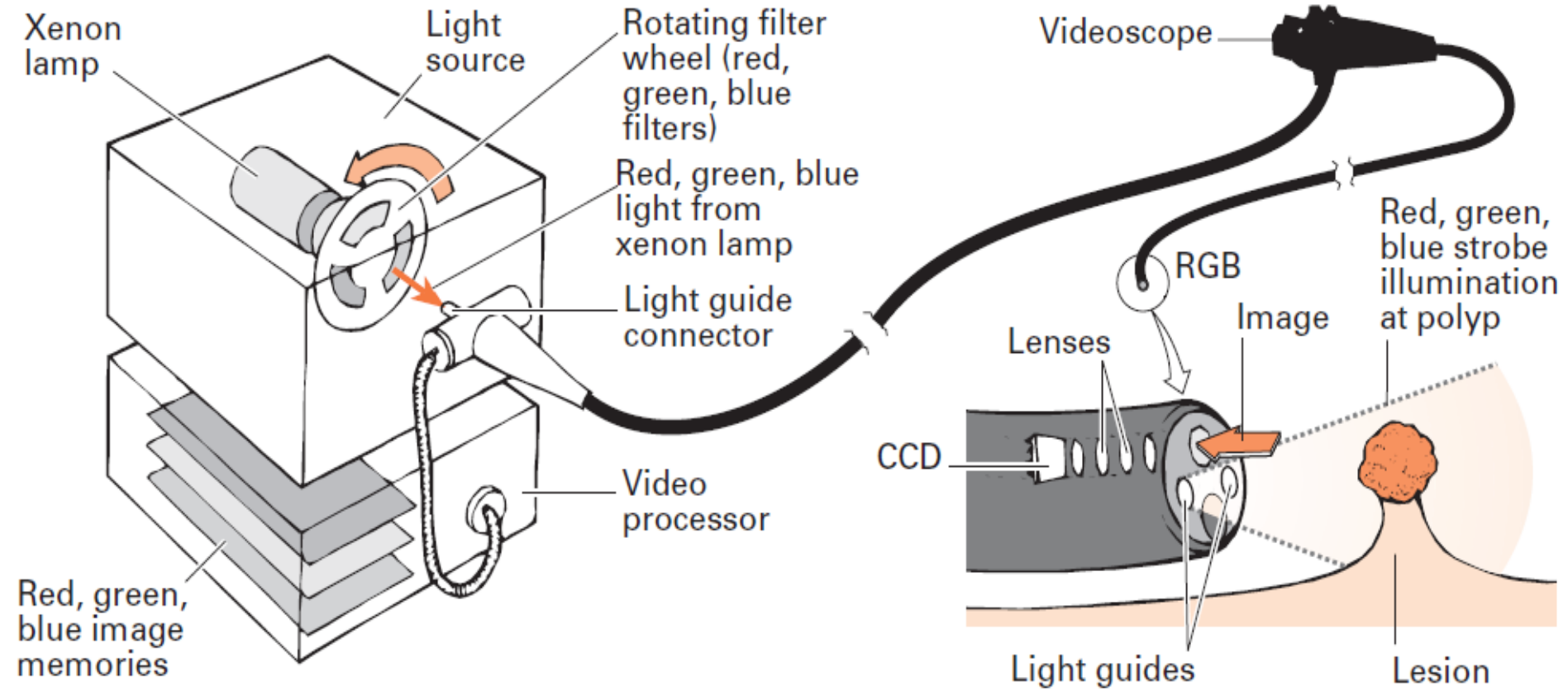

Fig. 1.5 Sequential colour illumination.

Video-endoscope or fibre-endoscope?

- The screen-image quality of present video-endoscopes equals that of present fibrescopes in both colour and resolution.
- Videoendoscopy scores greatly by the fact that everyone can view the image simultaneously, with a clarity previously restricted to the endoscopist alone (teaching side-arms and add-on television cameras introduce optical interference and reduce quality).
- Whereas optical fibre technology is near its maximum theoretical performance (since below the 6–8 μ m fibre diameter approached in modern bundles there is massive loss of light transmission), there is no reason why the 10 μ m pixel size of present CCDs should not be reduced to around 1 μ m.
- This means that future CCDs can be smaller, but also that the greatly increased numbers of pixels will increase resolution and allow the use of high-definition TV monitors.

- The objection that videoendoscopes introduce ‘artificial colour’ values is untenable since:
- (i) they can be shown in technical studies to give a remarkably faithful rendering of test charts;
- (ii) the visual assessment of lesions depends little on absolute colour values;
- (iii) there is the inescapable fact that individual perception of colour varies significantly — the extreme example being colour blindness.
- In terms of hard-copy imaging there is also a clear advantage in employing only the ocular lens system at the instrument tip without the degrading effects of transmission down an optical bundle and through a secondary lens system.
- Of crucial importance is the fact that the digital signal simplifies image recording and manipulation, and opens the way for new methods of image enhancement, transmission and analysis.

- For the fibre-endoscopist, the mechanical transition to handling video-endoscopes whilst viewing the TV monitor is mastered in a few minutes.
- Thereafter, most endoscopists tend to work this way instinctively, even with fibre-endoscopes if a video camera attachment is available.
- The ease of stance, brighter view and the natural visual field (combining a macular view of the image and peripheral view of the patient and the endoscopy room) make video-endoscopes extremely relaxing to use, and facilitates communication with patients and assistants.

Illumination

- This is provided from an external high-intensity source through one or more light-carrying bundles.
- These may be xenon arc (300W) or halogen-filled tungsten filament lamps (150W).
- Light is focused by a parabolic mirror onto the face of the bundle, and the transmitted intensity is controlled by filters and/or a mechanical diaphragm.
- The light sources made by different companies are not always interchangeable; adapters may be provided, but involve a further optical interface and some loss of light.
- Small sources are mobile and relatively cheap and provide sufficient illumination for simple observation and standard photography.
- Large light sources are necessary for optimal photography and television application when using fibrescopes or video-endoscopes.

Instrument tip

- Control of the instrument tip depends upon pull wires attached at the tip just beneath its outer protective shaft, and passing back through the length of the instrument shaft to the angling controls in the control head (Fig.·1.6).
- The two angling wheels/knobs (for up/down and right/left movement) incorporate a friction braking system, so that the tip can be fixed temporarily in any desired position; angling with the brakes on causes no damage.
- The instrument shaft is torque stable so that rotatory ‘corkscrewing’ movements applied to the head are transmitted to the tip—if the shaft is relatively straight at the time.

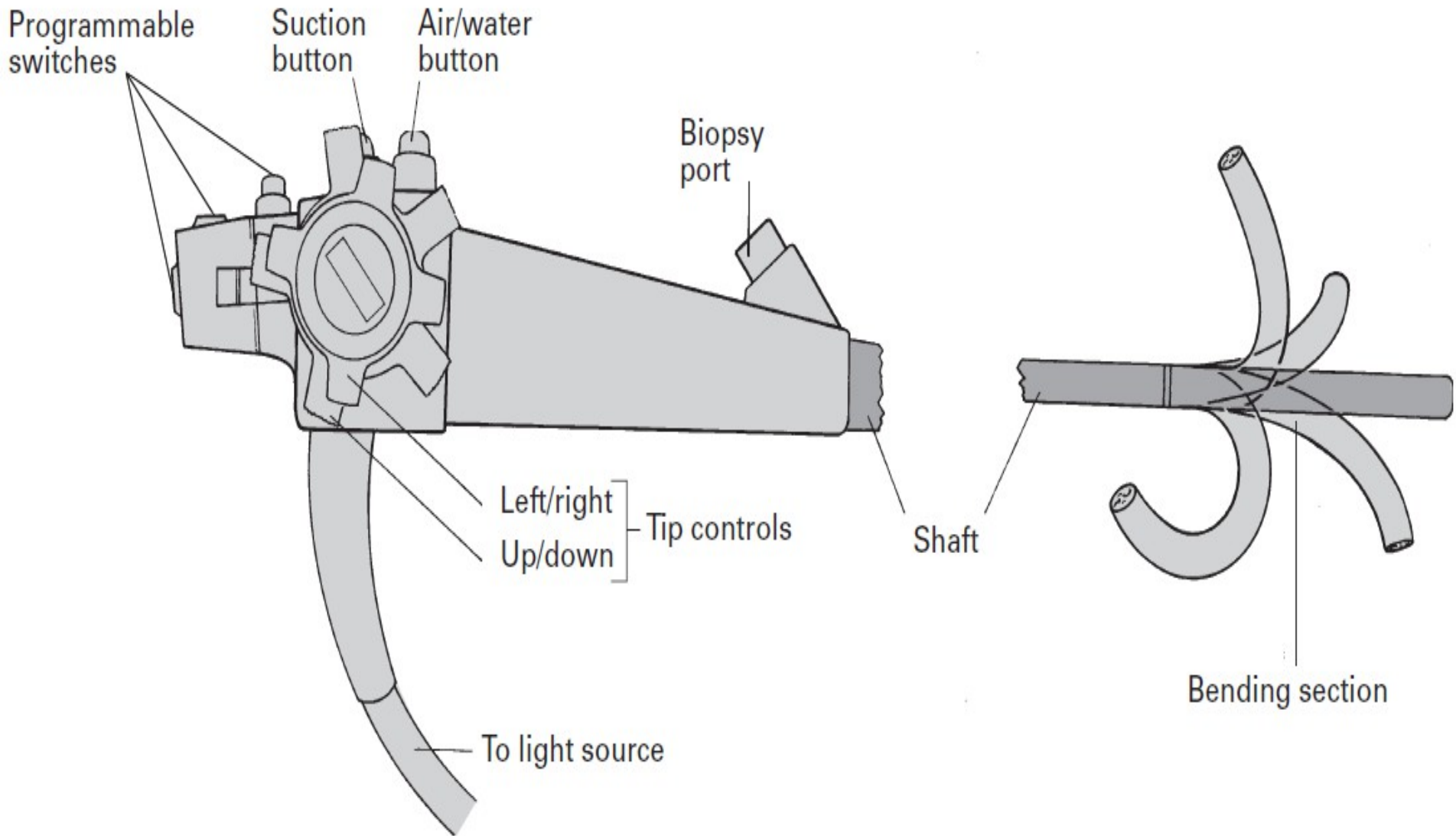

Fig. 1.6 Basic design—control head and bending section.

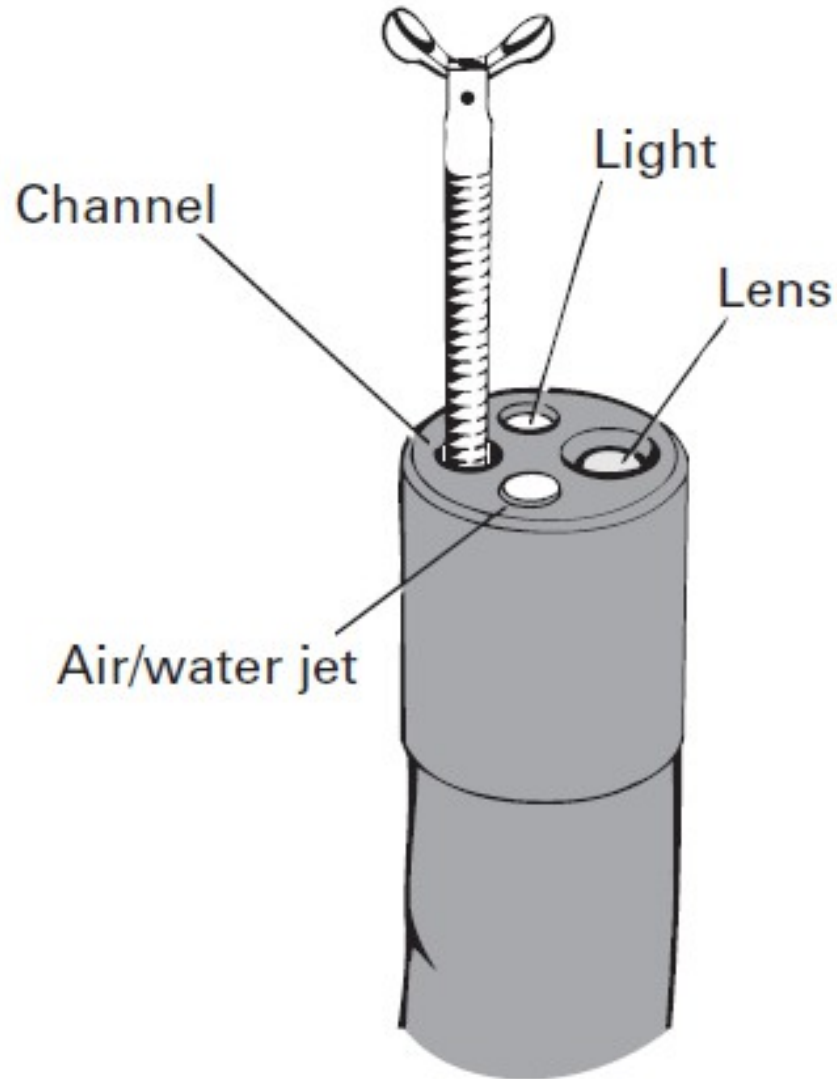
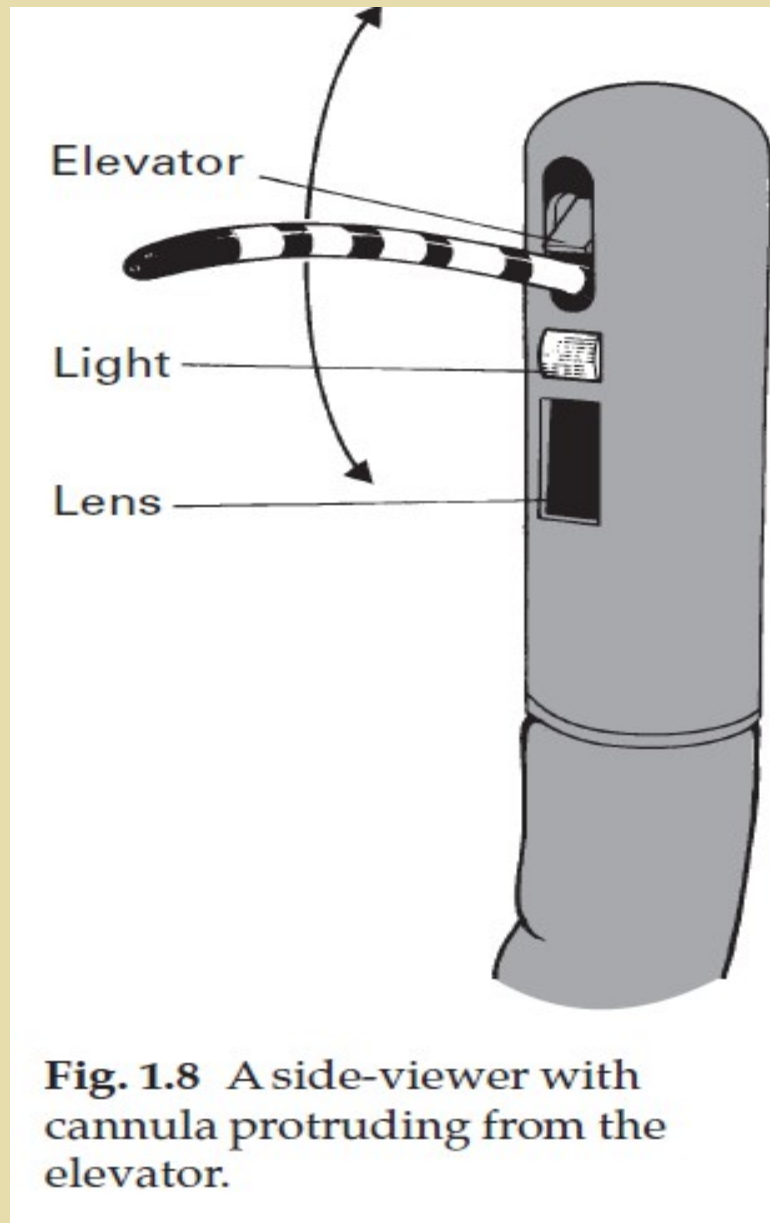

Fig. 1.7 The tip of a forward-viewing endoscope.



Instrument channels

- An 'operating' channel (usually 2–4mm in diameter) allows the passage of fine flexible accessories (e.g. biopsy forceps, cytology brushes, sclerotherapy needles, diathermy snares) from a port on the endoscope control head (see Fig.·1.6) through the shaft and into the field of view (Fig.·1.7).
- In some instruments (especially those with lateral-viewing optics), the tip of the channel incorporates a small deflectable elevator or bridge, which permits some directional control of the forceps and other accessories independent of the instrument tip (Fig.·1.8).
- This elevator or bridge is controlled by a further thumb lever.
- The operating channel is also used for aspiration in single-channel instruments; an external suction pump is connected to the 'umbilical' cord of the instrument near the light source and suction is diverted into the instrument channel by pressing the suction valve.

- The channel size varies with the instrument purpose.
- ‘Therapeutic’ endoscopes with large channels allow better suction and larger accessories.
- Twin-channel endoscopes exist for specialized applications.
- An ancillary small channel transmits air to distend the organ being examined; the air is supplied from a pump in the light source and is controlled by another valve (see Fig.1.6).
- The air system also pressurizes the water bottle so that a jet of water can be squirted across the distal lens to clean it.
- In colonoscopes there is a separate proximal opening for the water channel, to allow high-pressure flushing with a syringe.

Tissue-sampling devices

- Forceps consist of a pair of sharpened cups (Fig.·1.9), a spiral metal cable and a control handle (Fig.·1.10).
- The maximum diameter is limited by the size of the operating channel, and the length of the cups by the radius of curvature through which they must pass in the instrument tip.
- This may be acute in side-viewing instruments with forceps elevators.
- When it is necessary to take biopsy specimens from a lesion which can only be approached tangentially (e.g. the wall of the oesophagus), forceps with a central spike may be helpful; however, these present a significant puncture hazard, and should probably not be used to avoid accidental infectious inoculation of endoscopy staff.
- Cytology brushes have a covering plastic sleeve to protect the specimen during withdrawal (Fig.·1.11).

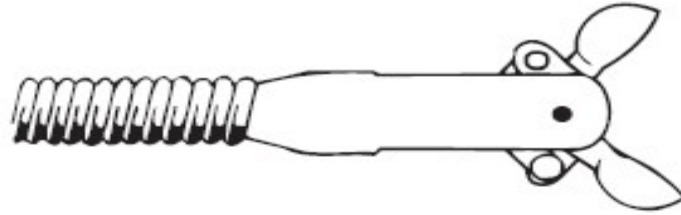

Fig. 1.9 Biopsy cups open.

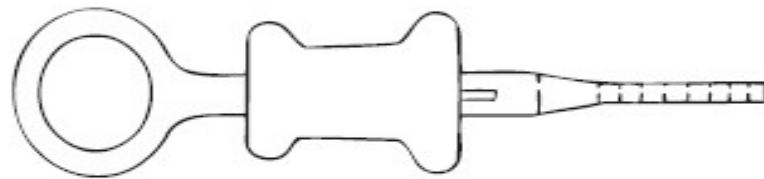

Fig. 1.10 Control handle for forceps.



Fig. 1.11 Cytology brush with outer sleeve.

Suction traps

- Suction traps, such as those used for collecting samples of sputum during bronchial aspiration, are equally useful for taking samples of intestinal secretions and bile.
- When fitted temporarily into the suction line (Fig.1.12) they allow the collection of samples for microbiology, chemistry and ‘salvage’ cytology.
- Solid or snare-loop specimens can also be retrieved in an ingenious filtered suction trap available commercially (Fig.1.13).

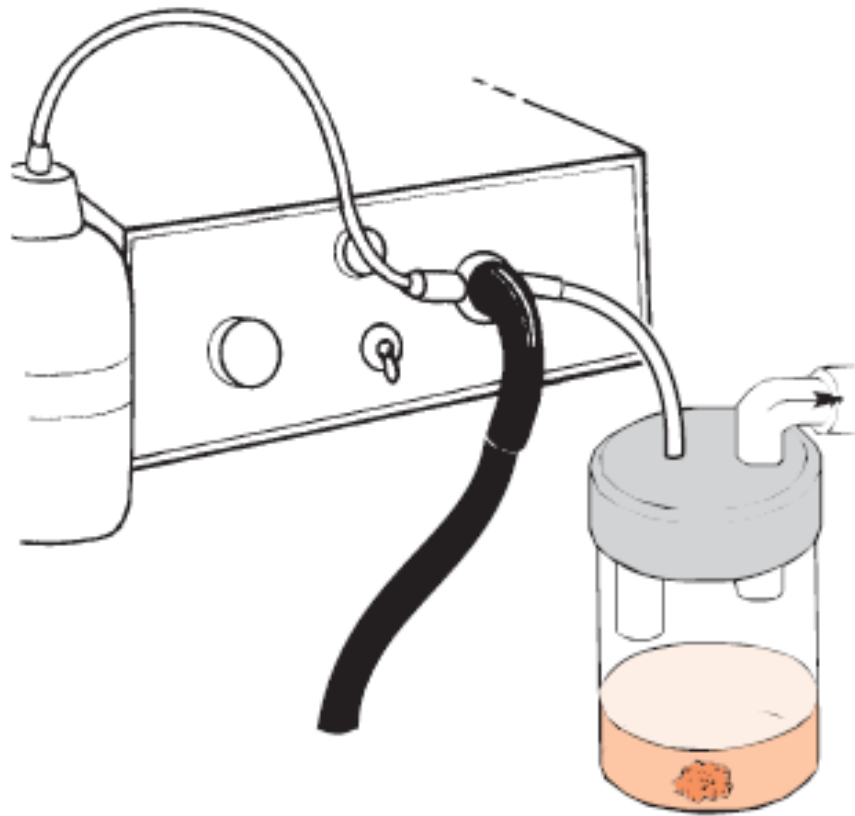

Fig. 1.12 A suction trap to collect fluid specimens.

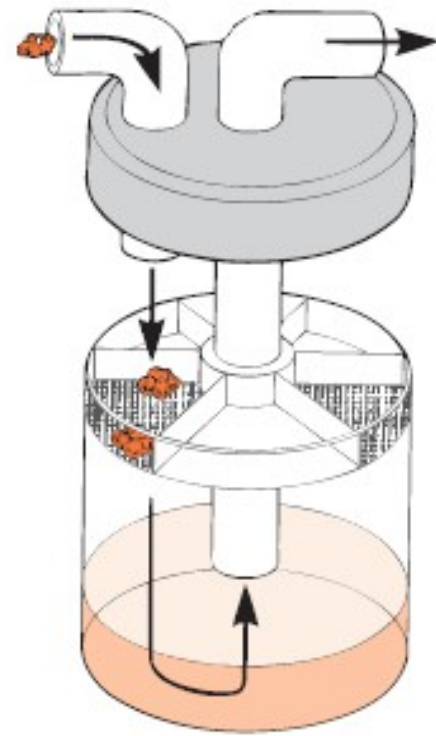

Fig. 1.13 A filtered suction trap is better for tissue specimens.

Fluid-flushing devices

- Flushing fluids through the channel may be necessary to provide optimal views of lesions, particularly in the presence of food residue or acute bleeding.
- With standard endoscopes, this can be done with a syringe, manual bulb (Fig. 1.14) or a pulsatile electric pump, with a suitable nozzle through the biopsy port.
- Some therapeutic instruments have an in-built forward-facing flushing channel at the tip.
- For more precise aiming, a simple Teflon tube can be passed down the instrument channel to clear mucus or blood from areas of interest with a jet of water, or to highlight mucosal detail by 'dye spraying' (using a nozzle-tipped catheter).

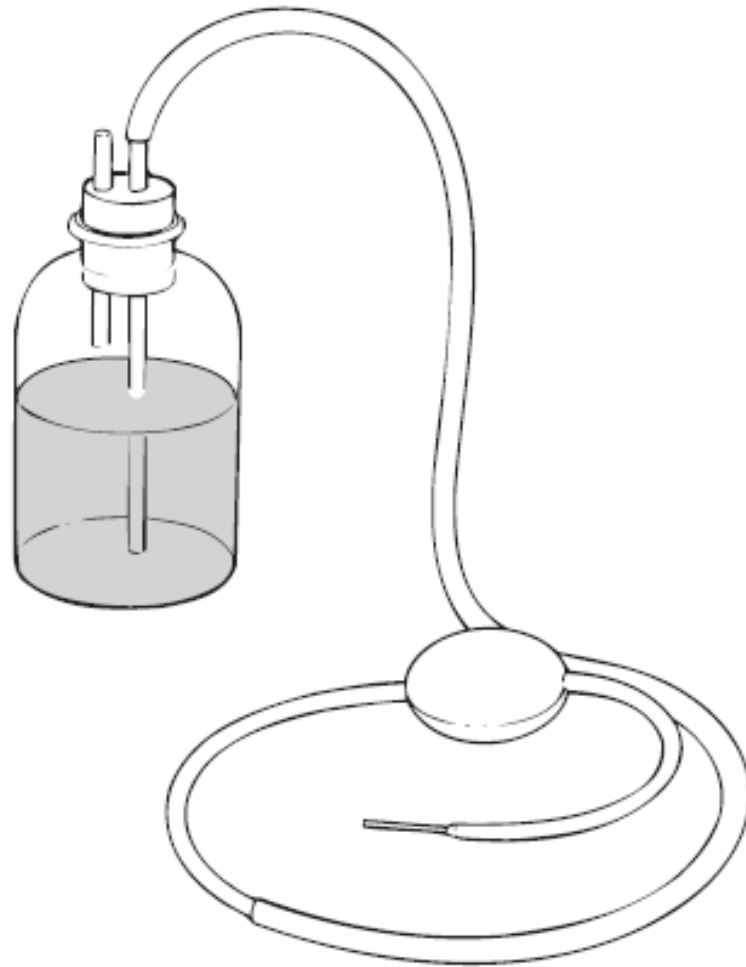

Fig. 1.14 A rubber bulb for flushing through the instrumentation channel.

Overtubes (sleeves)

- These are flexible hoses (24–45cm long, depending on the indication) designed to fit over the endoscope shaft (Fig. 1.15).
- Sophisticated low-friction versions are produced but suitable alternatives can be made from plastic hose; the internal diameter needs to be tailored to the size of the endoscope.
- The wall should be as thin as possible (to minimize patient discomfort) but should have sufficient strength not to kink and to maintain its shape when the endoscope is removed.
- The top end of the tube should have a flange which abuts against the mouthguard, or some device which can be gripped by the assistant (to prevent it from disappearing into the mouth or anus).
- Overtubes are mainly used when repeated intubation is anticipated, e.g. for change of endoscopes, removal of multiple polyps, variceal banding or use of muzzle-loaded forceps and biopsy capsules.
- The endoscope is passed in the usual way, with the overtube at the top of the shaft.
- Once the endoscope is in position, the overtube is lubricated and slid over the shaft.
- It is then simple to remove and to replace the endoscope without significant patient discomfort.

- Alternatively, the upper GI overtube can be passed first, sitting snugly on a large dilator (or lavage tube) (Fig. 1.15).
- The dilator is then withdrawn, leaving the overtube in place; this protects the airway and allows the passage of endoscopes without additional patient discomfort.
- Longer and larger overtubes are used for the removal of sharp foreign bodies from the stomach and, by some practitioners, windowed overtubes have been found useful during variceal injection sclerotherapy, especially during active bleeding.
- They can be used also as stiffening devices during colonoscopy and enteroscopy.

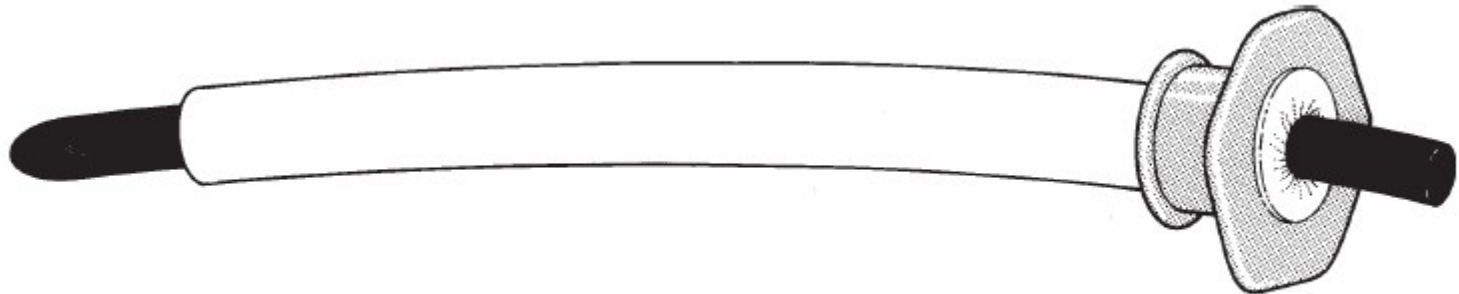

Fig. 1.15 An overtube with toothguard over a rubber lavage tube.

Brief History of Endoscopy

- **In the early 1900s, the first attempts to view inside the body with lighted telescopes were made. These initial devices were often fully rigid. In the 1930s, semi-flexible endoscopes called gastroscopes were developed to view inside of the stomach. Fiber-optic endoscopy was pioneered by South African-born physician Basil Hirschowitz at the University of Michigan in 1957. Widespread use of fiber optic endoscopes began in the 1960s.**
- **A fiber optic cable is simply a bundle of microscopic glass or plastic fibers that literally allows light and images to be transmitted through curved structures.**

ENDOSCOPY

FLEXIBLE ENDOSCOPY



SURGICAL ENDOSCOPY

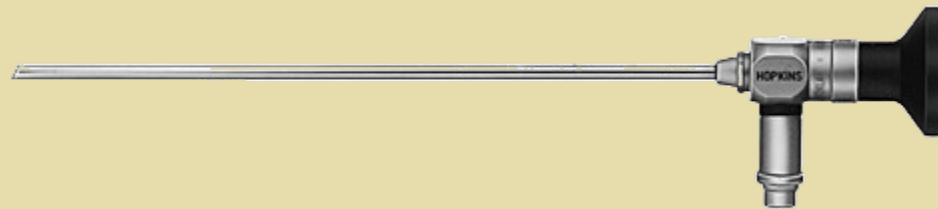

ENDOSCOPY

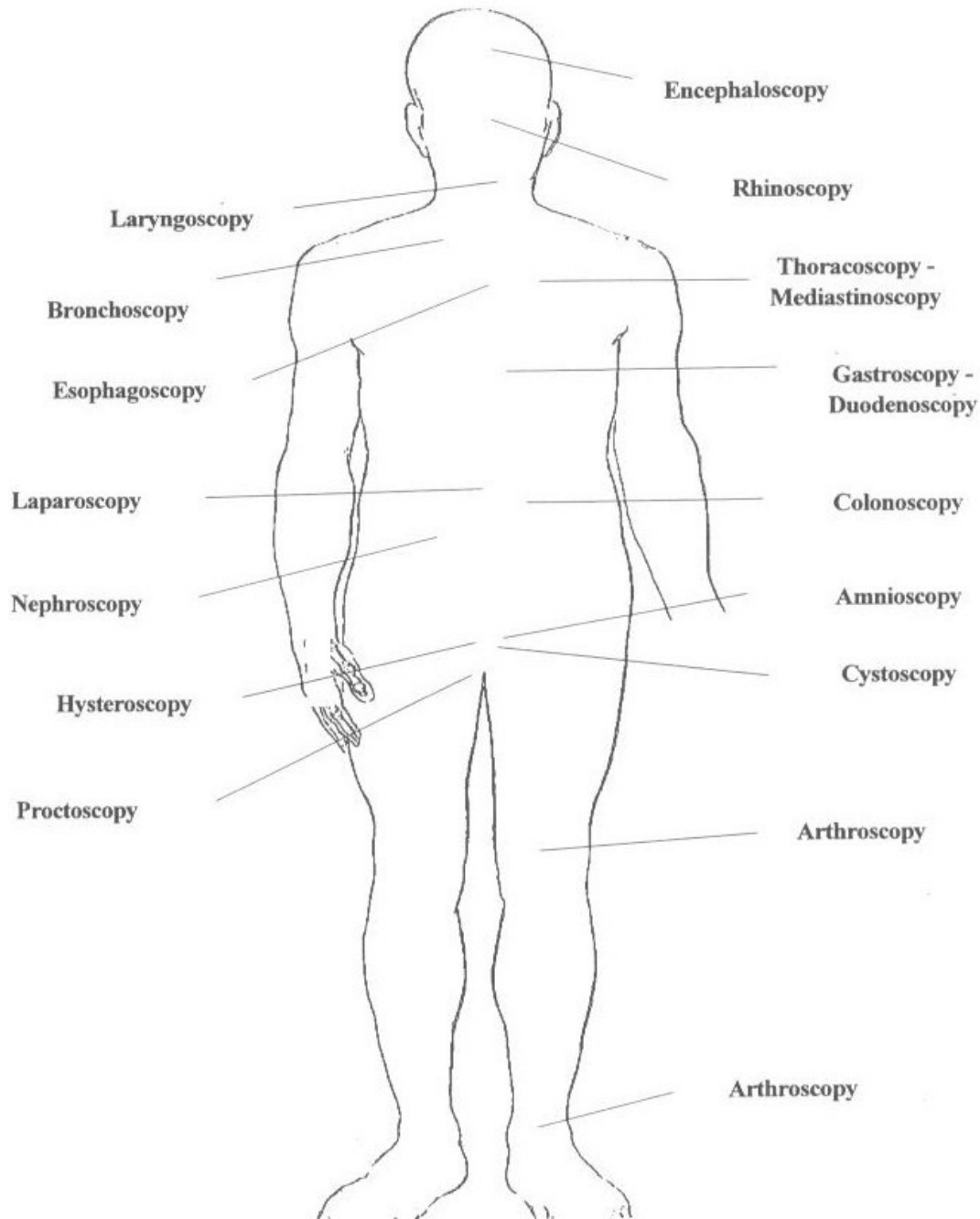

RIGID ENDOSCOPY

RIGID ENDOSCOPY

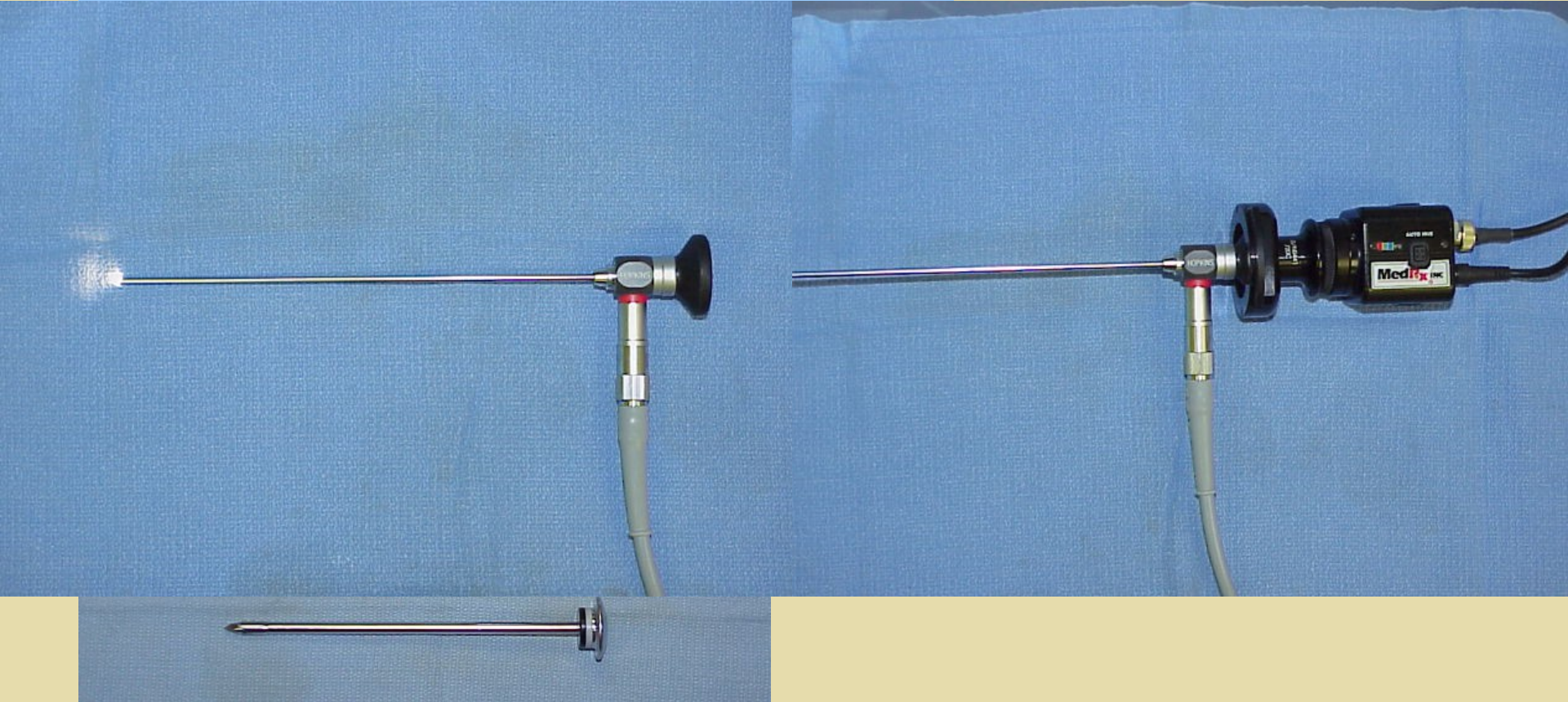

SURGICAL ENDOSCOPY (RIGID ENDOSCOPY)

- Laparoscopy.
- Arthroscopy.
- Endo-Urology.
- Gynecology.
- E.N.T-applications.
- Proctoscopy.
- . . . And many other surgical applications
(gastrectomy,neurosurgery,...etc) .

ARTHROSCOPY LAPAROSCOPY

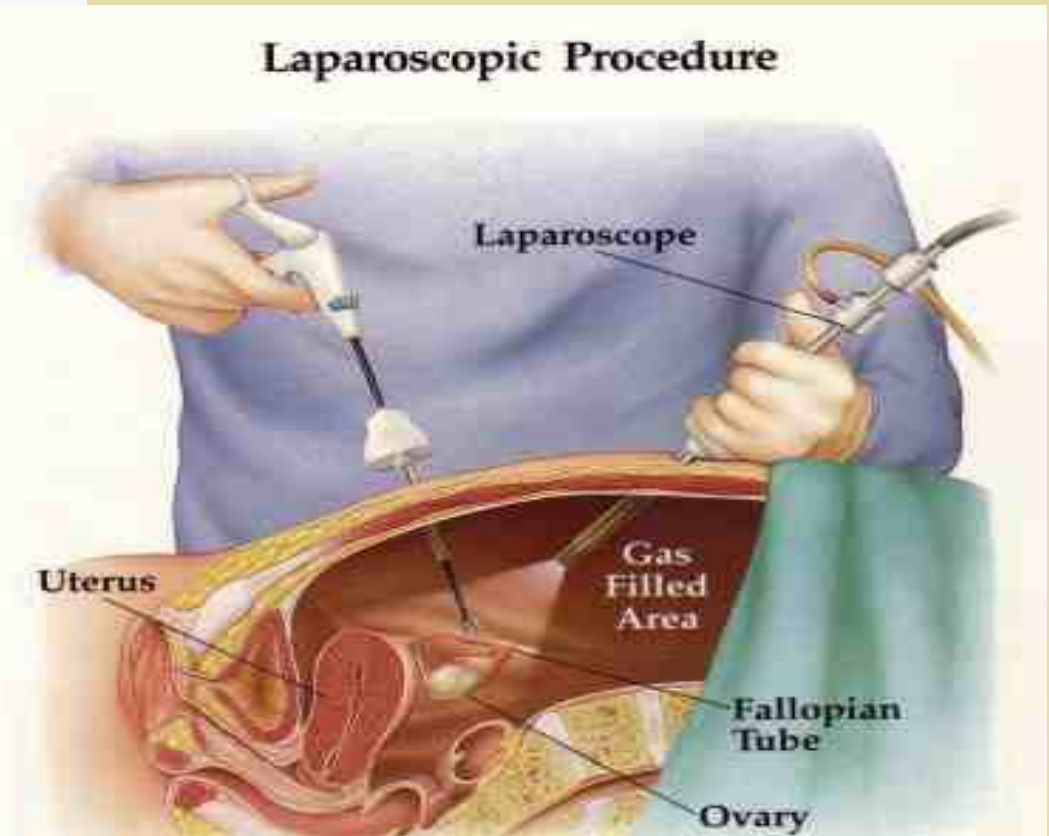
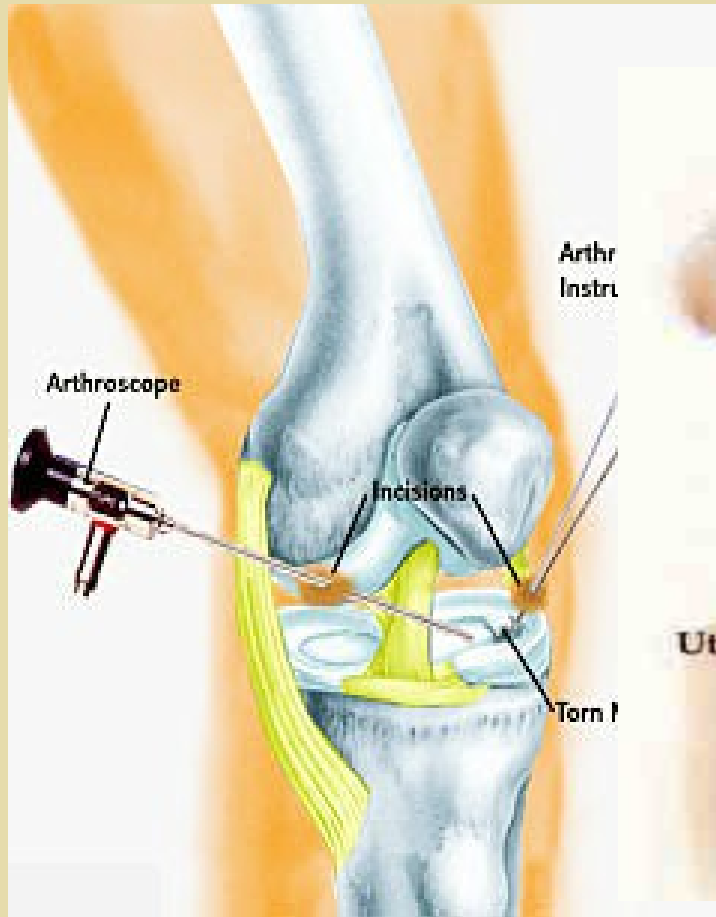

RIGID ENDOSCOPE

Rigid Endoscope

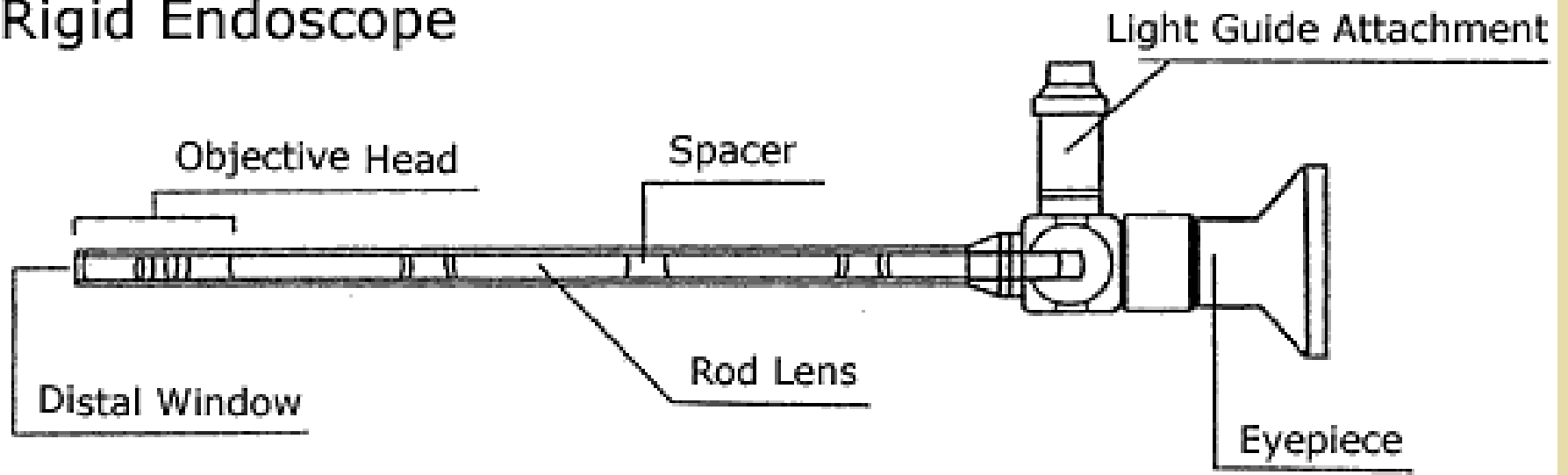

CARE OF RIGID ENDOSCOPE

- Rigid endoscopes must be handled with care, they are very delicate and can be damaged easily if dropped or hit against hard objects.
- Can be disinfected via gas sterilization or autoclaved if specified by manufacturer or soaked in 2-3% glutaraldehyde sol'n mostly used safe disinfection technique .

FLEXIBLE ENDOSCOPY

The Digestive System

- The **digestive** tract consists of the followings :
- Mouth
- Throat
- Esophagus
- Stomach
- Duodenum
- Small bowel
- Colon
- Rectum
- Anus
- And other GI organs .

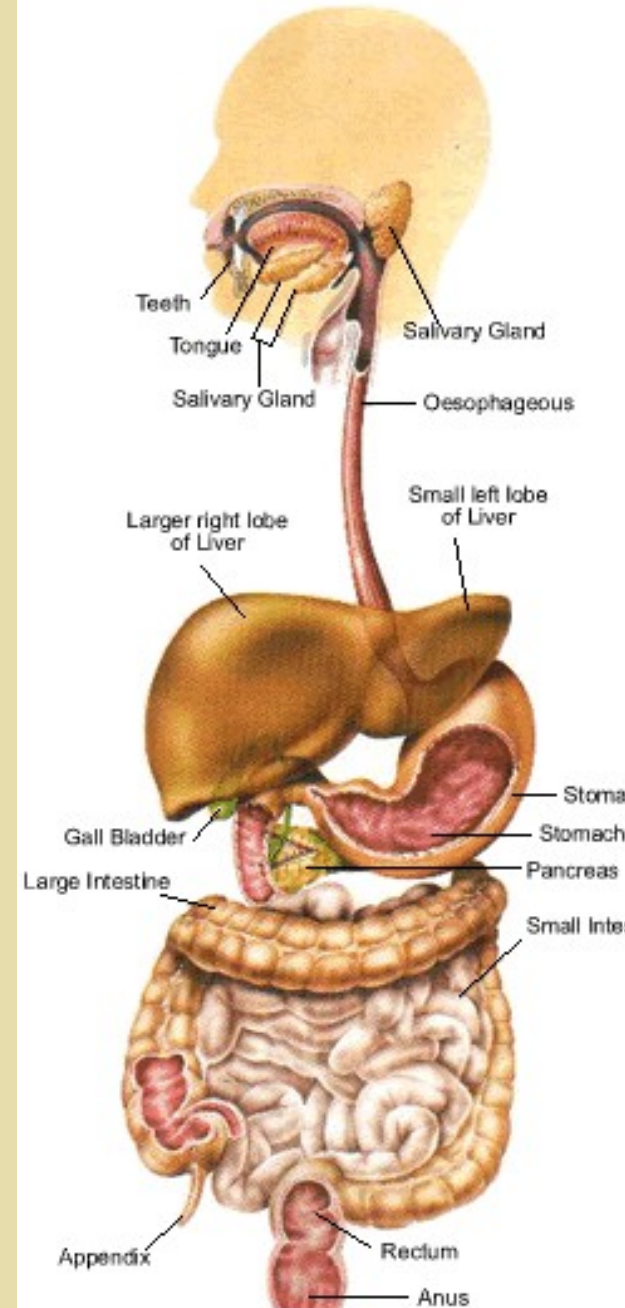

FLEXIBLE ENDOSCOPY

UPPER GI ENDOSCOPY

LOWER GI ENDOSCOPY

RESPIRATORY ENDOSCOPY

UPPER GI ENDOSCOPY

Gastroscopy

Duodenoscopy
(ERCP)

Enteroscopy

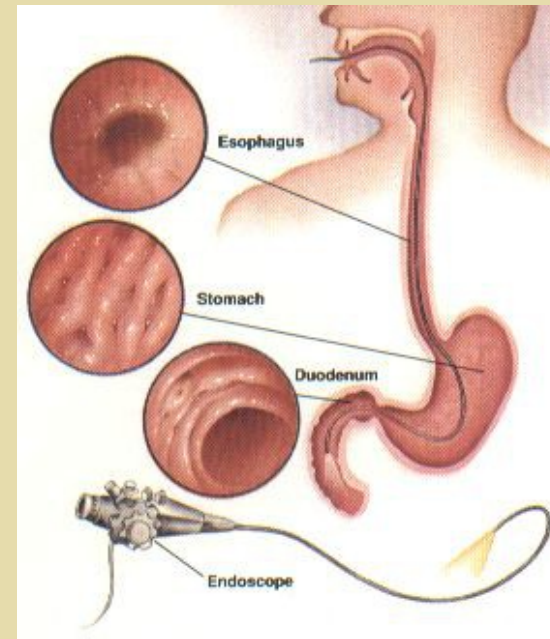
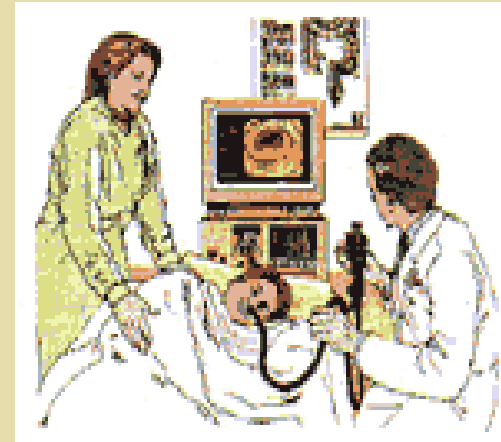

GASTROSCOPY

- **Upper endoscopy(gastroscopy) enables the physician to look inside the esophagus, stomach, and duodenum and the first part of the small intestine. The procedure might be used to discover the reason for swallowing difficulties, reflux, bleeding, indigestion, abdominal pain, or chest pain.**
- **Procedure: swallow a thin, flexible, lighted tube called an endoscope . Right before the procedure the physician will spray your throat with a numbing agent that may help prevent gagging. You may also receive pain medicine and a sedative to help you relax during the exam. The endoscope transmits an image of the inside of the esophagus, stomach, and duodenum, so the physician can carefully examine the lining of these organs. The scope also blows air into the stomach; this expands the folds of tissue and makes it easier for the physician to examine the stomach.**
- **Gastroscopy takes around 10 minutes .**

ERCP

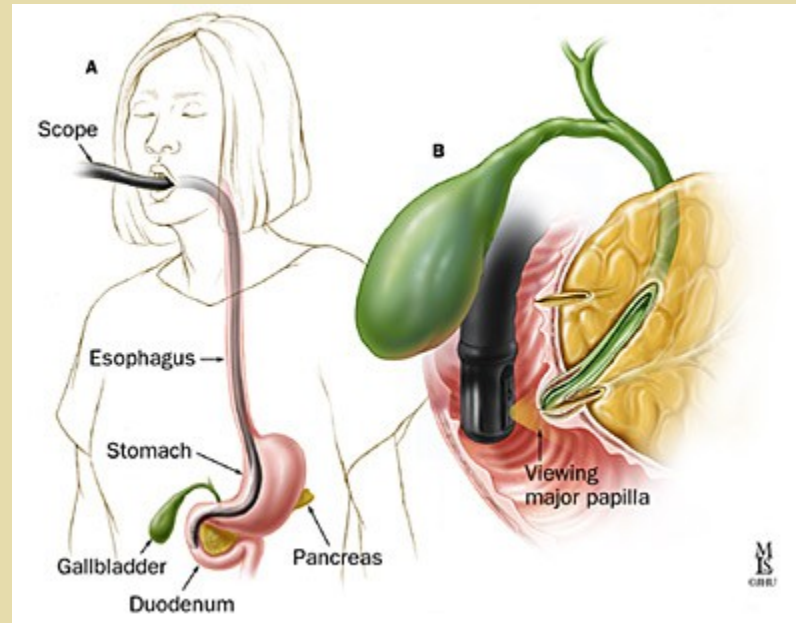

DUODENOSCOPY(ERCP)

- **ERCP combines the use of x rays and an endoscope, which is a long, flexible, lighted tube. Through it, the physician can see the inside of the stomach and duodenum, and inject dyes into the ducts in the biliary tree and pancreas so they can be seen on x ray .**

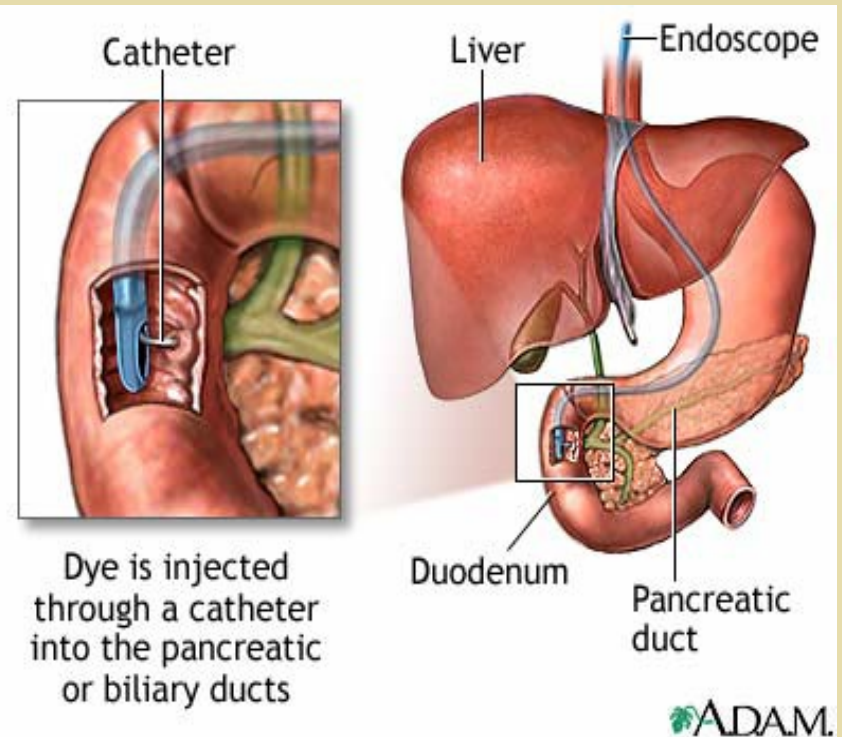

DUODENOSCOPY(ERCP)

Endoscopic retrograde cholangiopancreatography (ERCP) enables the physician to diagnose problems in the liver, gallbladder, bile ducts, and pancreas.

The liver is a large organ that, among other things, makes a liquid called bile that helps with digestion.

The gallbladder is a small, pear-shaped organ that stores bile until it is needed for digestion.

The bile ducts are tubes that carry bile from the liver to the gallbladder and small intestine.

These ducts are sometimes called the biliary tree. ERCP is used primarily to diagnose and treat conditions of the bile ducts including gallstones, inflammatory strictures (scars), leaks(from trauma and surgery), and cancer.

LOWER GI ENDOSCOPY

Colonoscopy

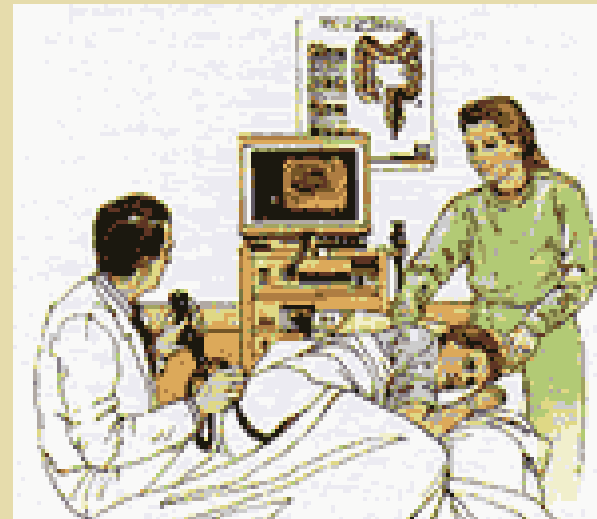

Sigmoidoscopy

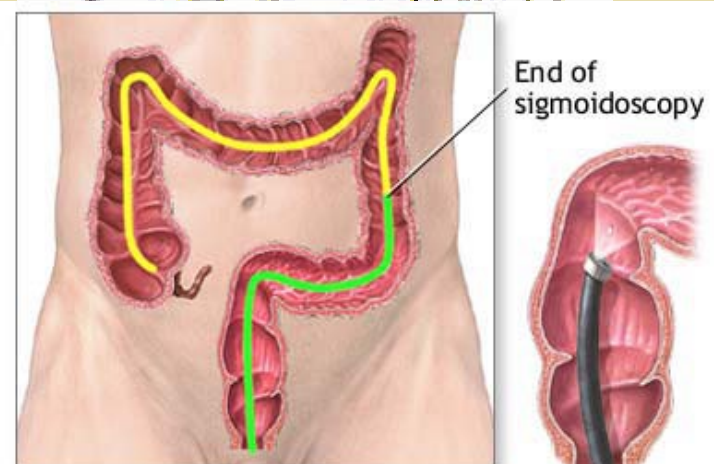

Colonoscopy examines the entire length of the colon; sigmoidoscopy examines only the lower third

COLONOSCOPY

- **Colonoscopy lets the physician look inside the entire large intestine, from the lowest part, the rectum, all the way up through the colon to the lower end of the small intestine. The procedure is used to look for early signs of cancer in the colon and rectum. Colonoscopy enables the physician to see inflamed tissue, abnormal growths, ulcers, and bleeding.**
- **If anything abnormal is seen in the colon, like a polyp or inflamed tissue, the physician can remove all or part of it using tiny instruments passed through the scope. That tissue (biopsy) is then sent to a lab for testing. If there is bleeding in the colon, the physician can pass a laser, heater probe, or electrical probe, or inject special medicines through the scope and use it to stop the bleeding.**
- **Colonoscopy takes 30 to 60 minutes.**

SIGMOIDOSCOPY

Flexible sigmoidoscopy enables the physician to look at the inside of the large intestine from the rectum through the last part of the colon, called the sigmoid or descending colon.

Physicians may use the procedure to find the cause of diarrhea, abdominal pain, or constipation.

They also use it to look for early signs of cancer in the descending colon and rectum.

With flexible sigmoidoscopy, the physician can see bleeding, inflammation, abnormal growths, and ulcers in the descending colon and rectum. Flexible sigmoidoscopy is not sufficient to detect polyps or cancer in the ascending or transverse colon two-thirds of the colon) .

RESPIRATORY ENDOSCOPY

Bronchoscopy

Laryngoscopy

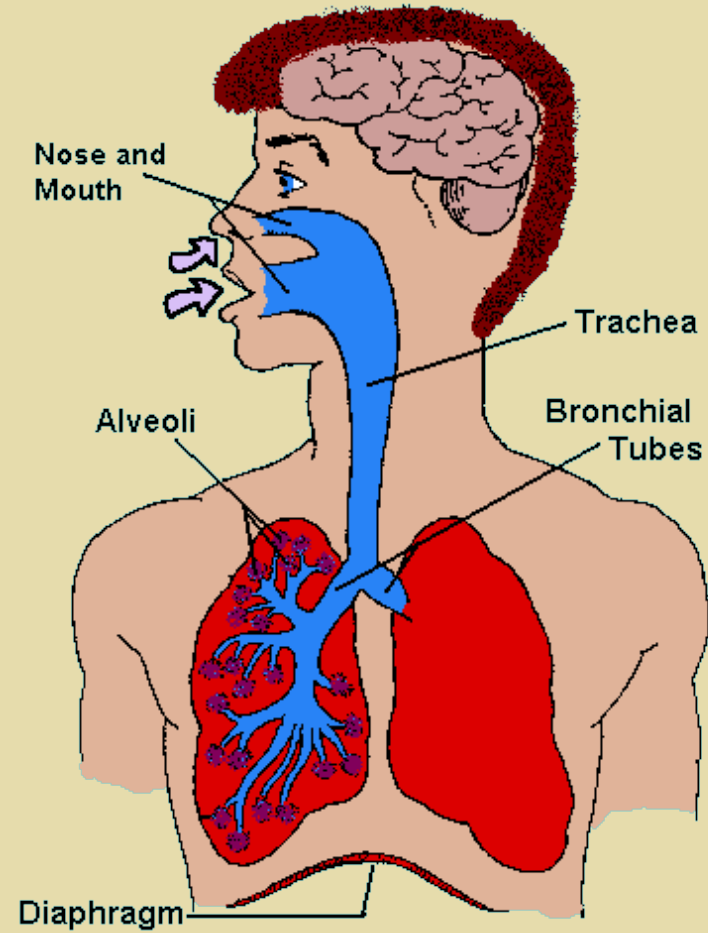

BRONCHOSCOPY

- **A bronchoscope is a tube with a tiny camera on the end which is inserted through the nose (or mouth) into the lungs. During a bronchoscopy procedure, a scope will be inserted through one nostril until it passes through the throat into the trachea and bronchi. A bronchoscope is used to provide a view of the airways of the lung. The scope also allows the doctor to collect sputum, secretions and lung tissue for biopsy for tissue specimens.**

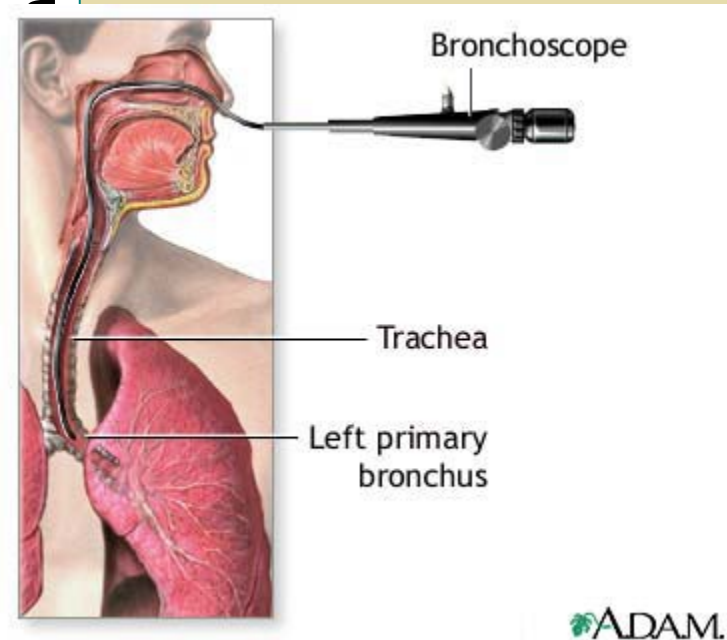

CYSTOSCOPY

- **Cystoscopy is a procedure that uses a flexible fiber optic scope inserted through the urethra into the urinary bladder. The physician fills the bladder with water and inspects the interior of the bladder. The image seen through the cystoscope may also be viewed on a color monitor and recorded on videotape for later evaluation.**

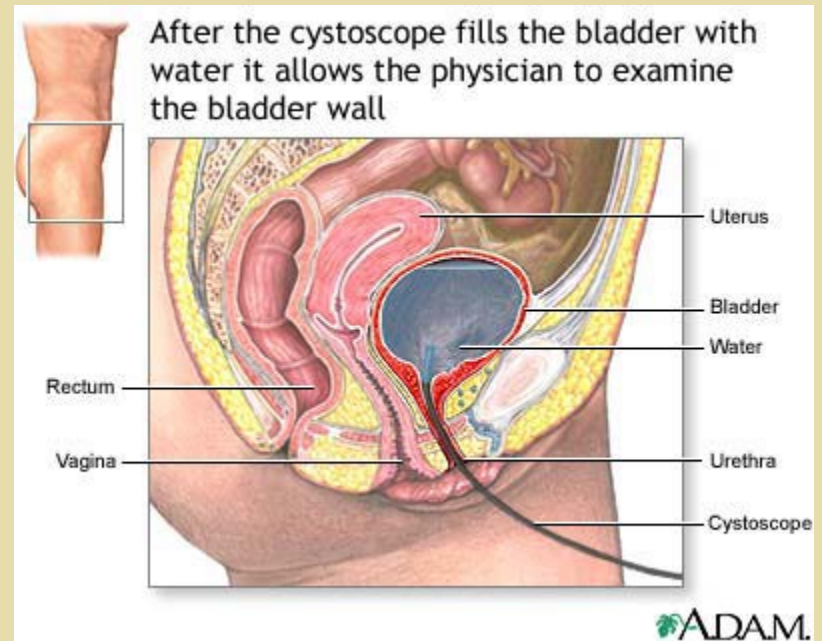

Endoscopy System

- Camera processor
- Monitor
- Light source
- Video recorder
- Video printer
- Suction system
- E.S.U
- Trolley with hanger
- Endoscope
- Endo-accessories



FLEXIBLE ENDOSCOPE

The flexible endoscope is a remarkable piece of equipment that can be directed and moved around the many bends in the gastrointestinal tract. Endoscopes now come in two types : The original pure fiberoptic instrument has a flexible bundle of glass fibers that collect the lighted image at one end and transfer the image to the eye piece. The newer video endoscopes have a tiny, optically sensitive computer chip at the end. Electronic signals are then transmitted up the scope to computer then displays the image on a large video screen. An open channel in these scopes allows other instruments to be passed through in order to take tissue samples, remove polyps and perform other exams.

FIBEROPTIC SCOPE

Fiberoptic Endoscope

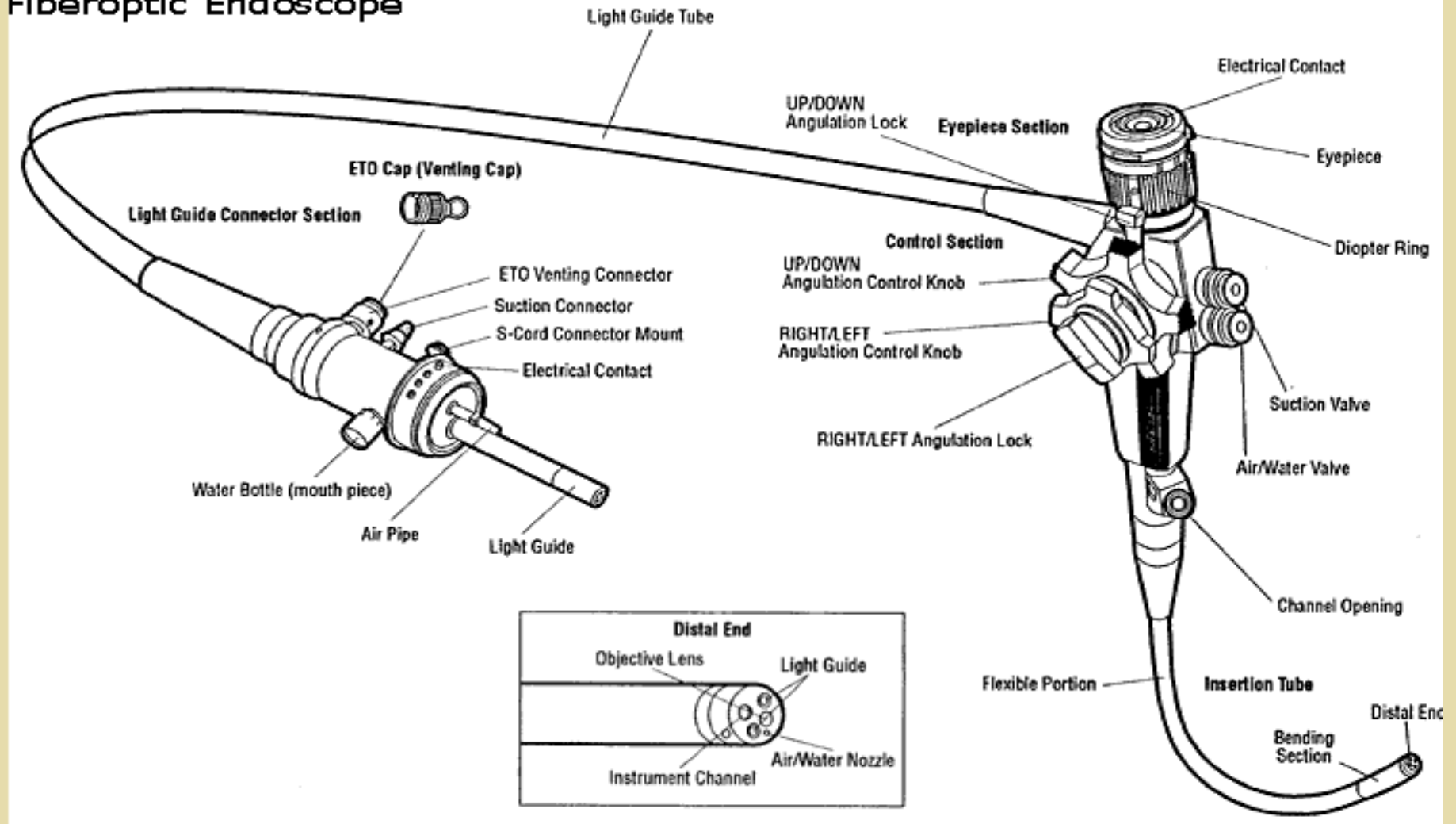

VIDEOSCOP

E

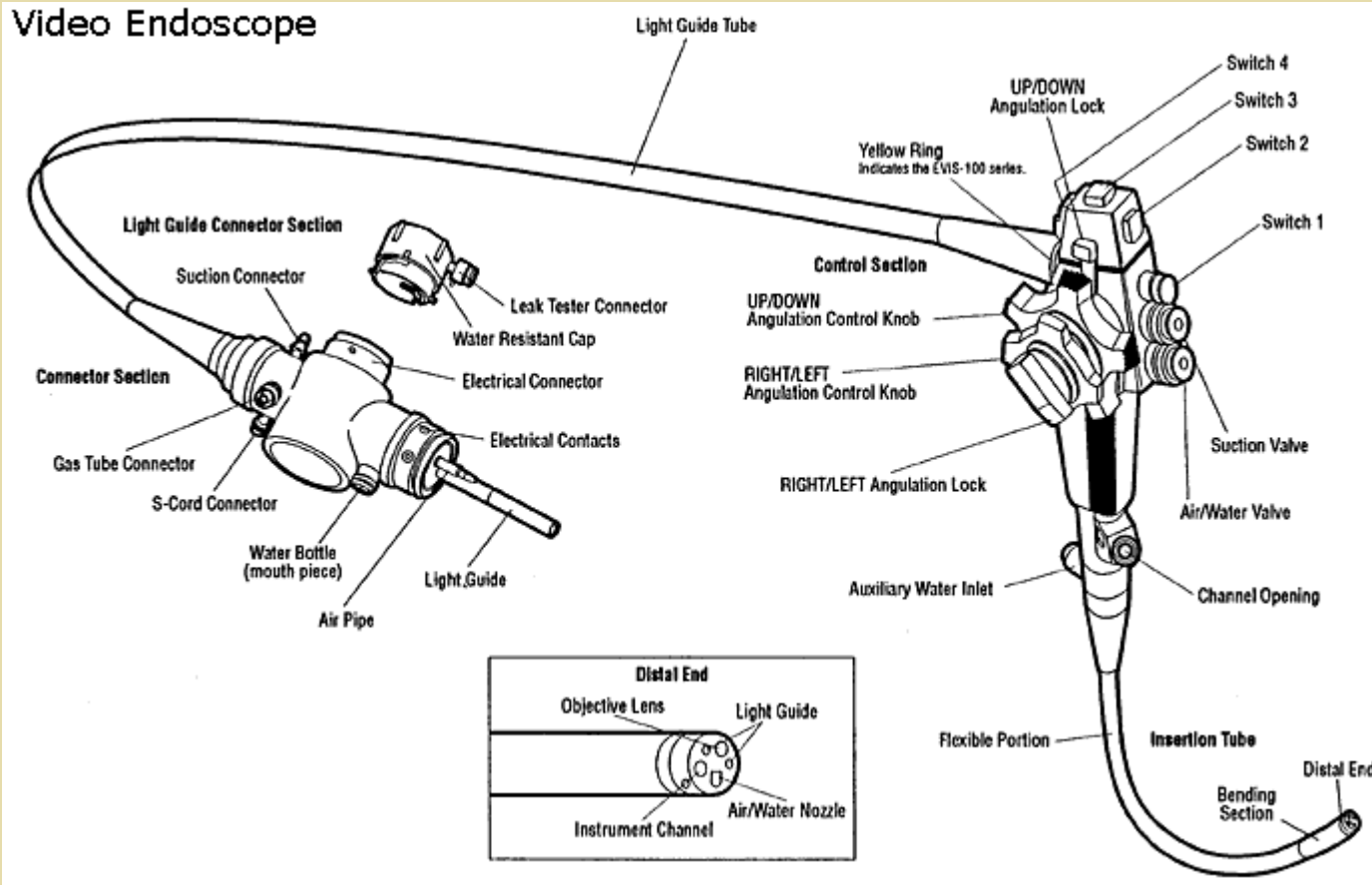

Construction of Flexible Endoscope

- Control Body
- Insertion Tube
- Light Guide Tube



Control Body

- Houses the following :
 - Angulation mechanism (drives)
 - Air/water and suction valves
 - Eye-piece (fiberscopes) or remote function buttons (videoscopes).



Insertion Tube

- Made of a complex plastic.
- Contains the following
 - LG fiber
 - A/W channel
 - Biopsy channel
 - Angulation wires
 - IG fiber or CCD

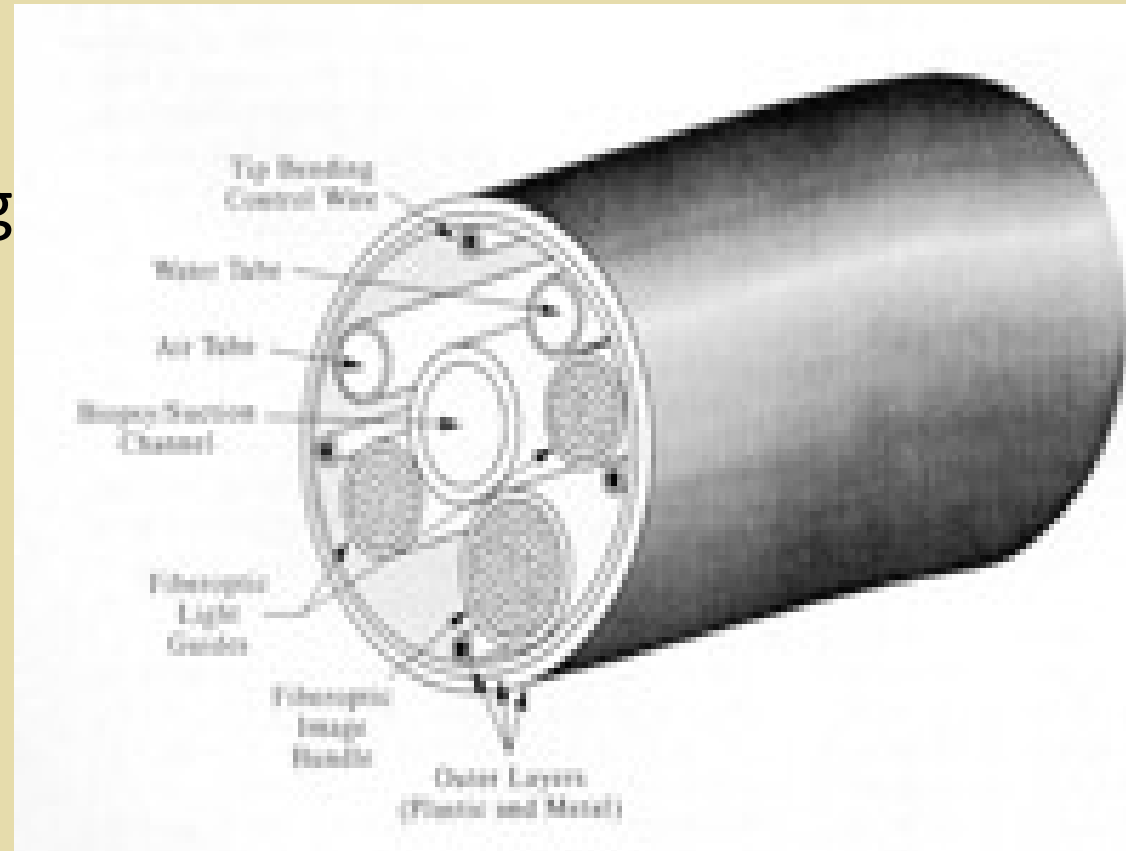

ENDOSCOPE CROSS SECTION

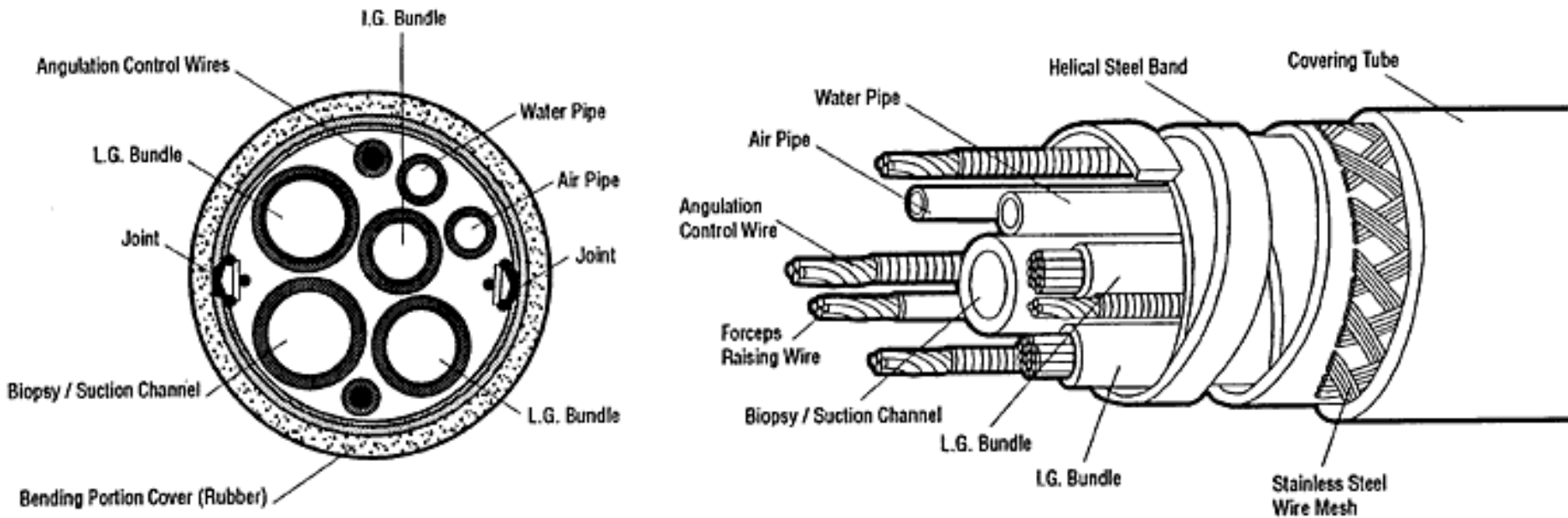

Light Guide Tube

- Contains the following:
 - LG fiber
 - Air channel
 - Water channel
 - Suction tube
 - CCD and/or control wires
 - LG plug



STANDARD CHANNELS - AIR, WATER & SUCTION

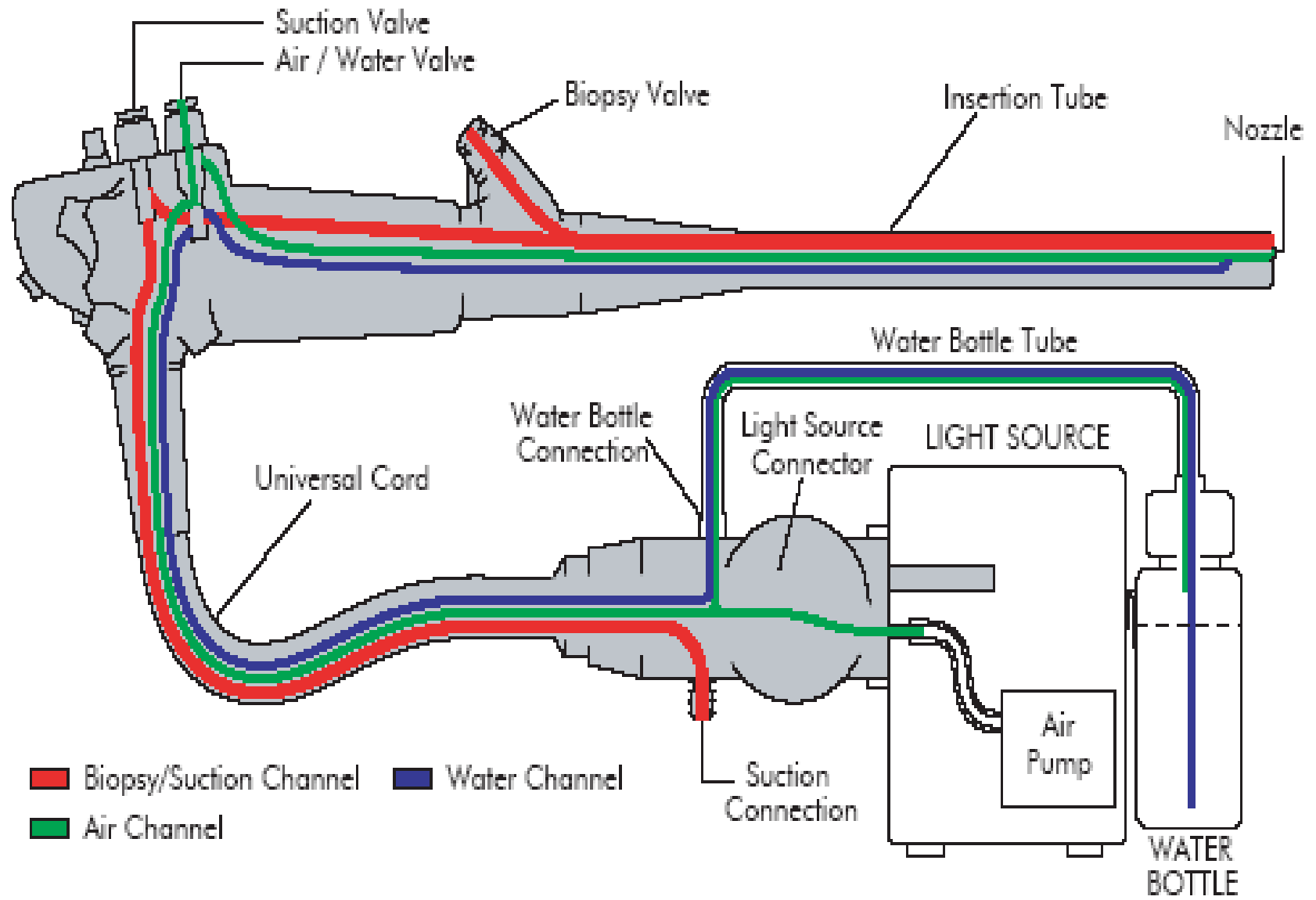

Anatomy of Endoscopy System

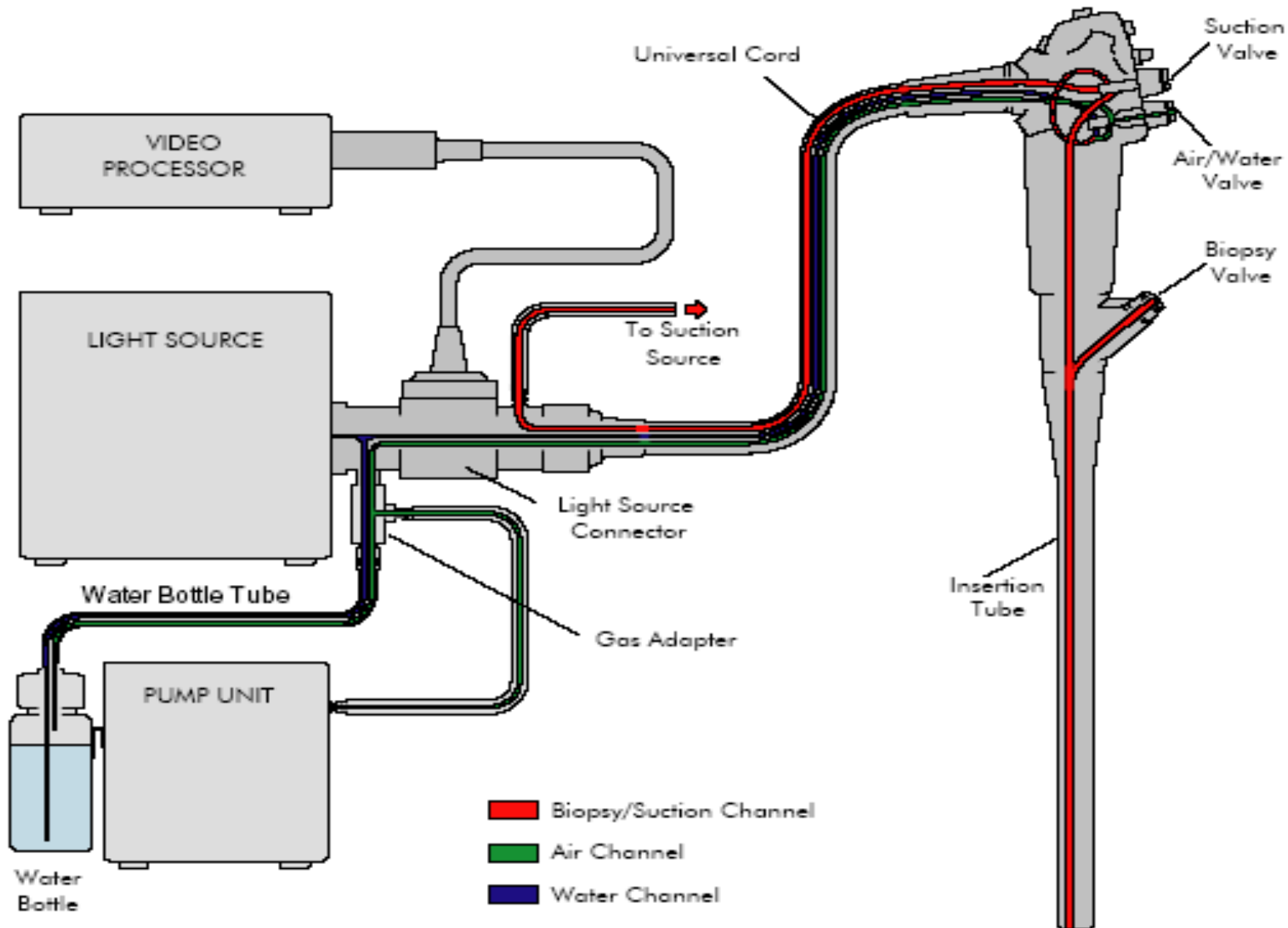

Endoscopic Accessories

- Biopsy forceps
- Graspers
- Baskets
- Injectors
- Dilators
- Knives
- HF endo-therapy accessories
- . . .And too many types of accessories.



PROCESSING OF ENDOSCOPES

- Mechanical Cleaning (wiping tubes and channel brushing in a detergent sol'n)
- Disinfection
- Rinsing



Endoscope Processing Fluids

- **Detergent** : medical grade, low foaming, neutral PH or enzymatic with proper dilution and temperature.
- **Disinfectant** : 2.0-3.0% Glauteraldehyde sol'n (mostly used and safe HLD).
- **Rinsing water** : Sterile water is needed to remove detergent and disinfectant residues, all channels must be flushed properly then endoscope to be dried by wiping and then hanged in the special endoscope cabinet

Flexible Care and Maintenance

- Endoscope must be inspected before and after use for the following :
 - Insertion and LG Tubes
 - Bending mechanism
 - Optical system
 - General inspection(appearance)
 - Endoscope to be leakage tested

Leakage Test

Endoscopes must be checked against any leak or damage before use and processing to ensure its efficiency and avoid instrument malfunction during endoscopy.

Leakage tester is an instrument which can be attached to endoscope and blows certain pressure of air-set by the manufacturer- inside it then endoscope is immersed in a water basin and checked against any leak, if any leak is seen endoscope must be immediately transferred for repair and must not be used.

FLEXIBLE ENDOSCOPE

TROUBLESHOOTING

Why do air/water problems occur?

- The scope is not cleaned immediately following procedure.
- Nozzle is damaged, missing or misaligned.
- Severe glutaraldehyde buildup from chemical disinfectants can break away from the channel and block the air/water nozzle.

How do bending sheaths become damaged?

- Any sharp objects, such as instruments, fingernails or bites can cause tears or holes in the sheath material.
- Over time, normal wear or over inflation can cause stretching or looseness of the bending rubber material.
- If the ETO cap is not in place during the ETO gas sterilization process, the scope will pressurize and the bending sheath will explode like a balloon. Follow the instructions on the white card attached to the ETO cap.

How do fluid problems occur?

- If a scope has a leak which is not detected, and the scope comes in contact with any fluid, moisture will enter the scope through the leak.
- In fiber scopes, the scope will have major fluid invasion if the scope is immersed with the ETO venting cap on. For video scopes, the water proof cap must be attached before contact with any fluid.
- If a scope has a fluid invasion and is not repaired immediately, video chip damage and image staining can result, as well as corrosion of the internal metal components.
- Remember - fluid problems are a scope's worst enemy!

Angulation problems are a result of :

- The angulation wires can stretch and break if the angulation is forced.
- Buckling of the insertion tube can stretch and break wires.
- Play in the angulation control knobs usually indicates an angulation adjustment is needed.

What causes damage to the channel?

- Kinked, damaged or open flexible biopsy forceps can cause tears in the channel material.
- Buckling of the insertion tube can cause buckles in the channel.
- Forcing instrumentation through the channel can cause wear or tears in the channel material. This frequently occurs in the bending section when resistance is met while the scope is angulated. Do not pass anything through the bending section with the tip angulated further than 110°.

How do image and light guide problems occur?

- Buckles or bites in the insertion or light guide tubes can break image and light guide fibers.
- Fluid invasion can cause staining of the fibers or video chip damage if not repaired immediately. The fluid also causes brittleness of the fiber bundles.
- Pulling on the insertion or light guide tube, as well as dropping the scope, can cause broken fibers or damage to the video chip.

HOW TO AVOID REPAIR

- Proper handling of endoscope.
- Using recommended accessories correctly.
- Proper processing and using protecting cover in case of videoscopes.
- Avoid harmful shaking,dropping or hitting against any hard object.
- Leakage test before and after use.
- Storing in clean,dry,well ventilated and maintained at normal temperature.
- **FOR ANY QUIRY DON'T TRY TO DISCOVER BY YOURSELF ASK ABOUT IT.....**

Capsule endoscopy



Scientists recently devised a disposable flash camera only slightly larger than a vitamin pill. In a procedure called capsule endoscopy, the patient swallows the minicam, which then takes pictures inside the small intestine. On its journey through the digestive tract, the tiny tumbling camera transmits images that are stored in a recorder that the person wears around the waist. After 8 hours, the camera's battery runs out, and the capsule is eliminated in the faeces. Scientists then download the recorder's images into a computer.

Bronchoscopy

Bronchoscopy

- It allows an assessment of the anatomy and function of the complete
- upper airway from the nasal passage, pharynx, and larynx to the segment bronchi.
- Diagnostic procedures such as bronchoalveolar lavage, as well as interventional procedures such as extraction of foreign bodies, can be performed with special instruments.

Diagnostic Bronchoscopy

- Stridor is a clinical sign for obstruction of the upper airway.
- Inspiratory stridor usually indicates an obstruction of the extrathoracic part of the airway.
- Expiratory stridor indicates an obstruction of the intrathoracic part of the airway.

congenital inspiratory stridor

- In most cases, congenital inspiratory stridor is caused by laryngomalacia.
- It should be investigated endoscopically when it is progressive or causes apnoea, feeding difficulties and growth retardation, or when symptoms point to a diagnosis other than laryngomalacia.
- In these cases, one may find bilateral vocal cord paralysis, subglottic hemangioma, or laryngeal cysts.
- Proper diagnosis of congenital inspiratory stridor can be done only with the child breathing spontaneously.

Acquired inspiratory stridor

- Acquired inspiratory stridor may originate from subglottic scar tissue, ductal cysts, or laryngeal papillomas.
- Expiratory stridor may be caused by asthma but also may be due to inhaled foreign bodies and tracheomalacia as a result of tracheobronchial or vascular malformations.

Interventional Bronchoscopy

Foreign body inhalation

- Symptoms of foreign body inhalation vary.
- There can be complete obstruction with hypoxia, bradycardia, and cardiac arrest, but if the object is small and passes beyond the main bronchi, the child may quickly become asymptomatic and be presented only when symptoms of distal obstruction occur.
- The majority of inhaled foreign bodies are radiolucent.
- A chest x-ray may show unilateral hyperinflation of the affected side as well as collapse and consolidation distal to the obstruction, but it may also be without pathologic findings

Airway stenosis

- An important indication for interventional bronchoscopy is treatment of airway stenoses.
- Laser therapy of subglottic haemangiomas is favoured by some, whereas others use application of intralesional steroids followed by intubation.
- Subglottic granulation tissue and viral papillomas can be treated with the intralesional injection of drugs (corticosteroids and chemotherapeutic agents).
- Subglottic cysts, which can develop after intubation, can be resected with a laser or with special forceps.
- These interventions require the availability of an intensive care unit because many children need to remain intubated due to secondary swelling of the subglottic area.

Rigid bronchoscopes

- Rigid ventilation bronchoscopes consist of a light metal tube.
- A port at the distal end allows the attachment of an anaesthetic T-piece for ventilation.
- Light is transmitted over a prism at the distal end of the tube.
- The ventilation scope can be used with spontaneous or controlled breathing.
- The scope can be used with the Hopkins rod telescope for diagnostic procedures (Figure 41.5).
- With the telescope in place, ventilation and examination are possible under excellent visual conditions.
- However, the telescope narrows the lumen of the bronchoscope, increasing airflow resistance and making breathing difficult.
- This is particular a problem with the smallest bronchoscopes.
- For therapeutic procedures the ventilation bronchoscope is used with special equipment, such as grasping forceps, for extraction of foreign bodies.

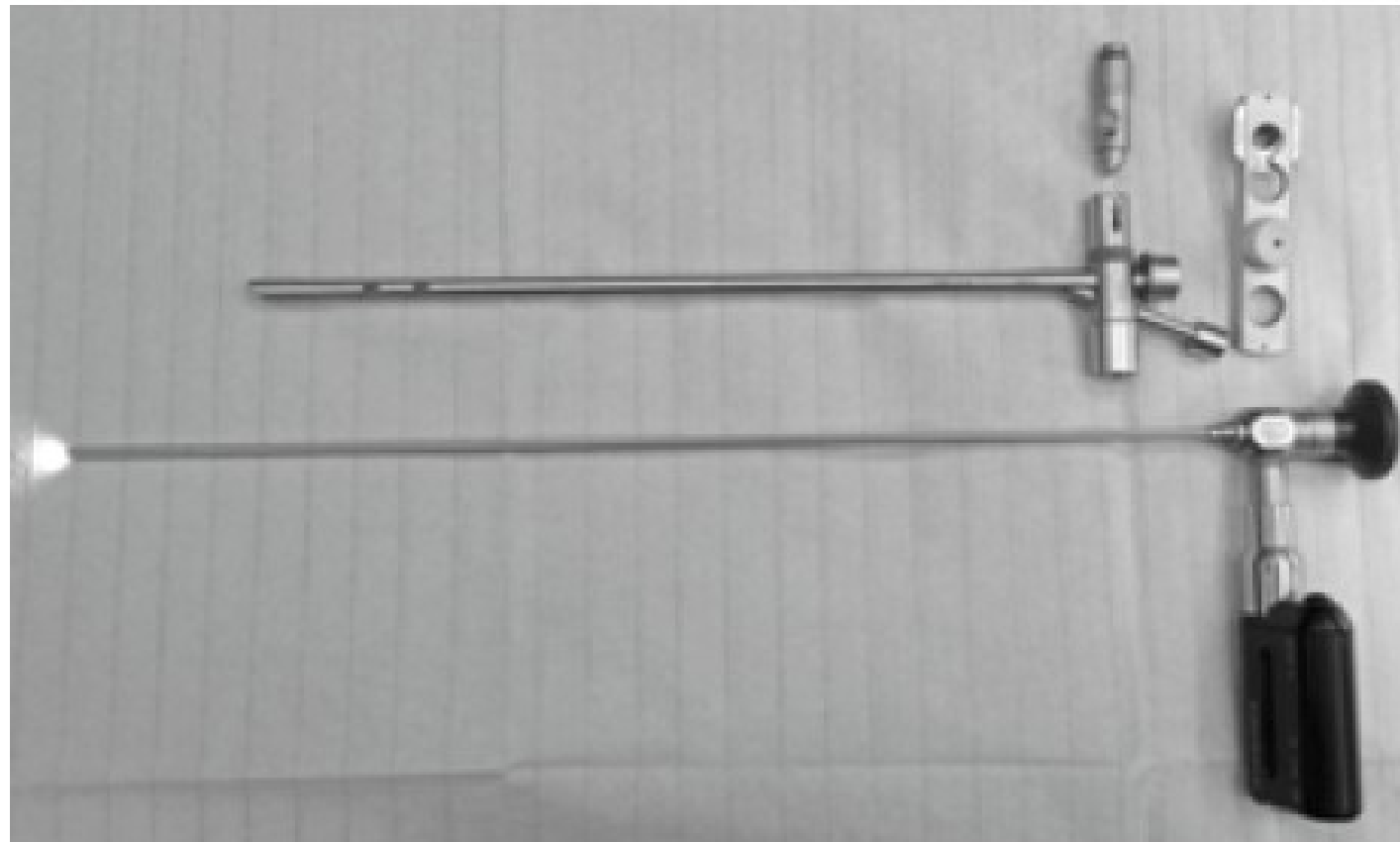

Figure 41.5: Storz ventilation bronchoscope with Hopkins rod telescope. A battery-powered light source is connected to the telescope.

The Hopkins rod telescope

- The Hopkins rod telescope is an endoscopic telescope in which the air-containing spaces between the conventional series of lenses are replaced with glass rods with polished ends separated by small air lenses.
- This system transmits more light, yields greater magnification, and provides greater depth and breadth of field than conventional lens systems.
- The instrument is inserted under direct laryngoscopy with a standard laryngoscope through the mouth under general anaesthesia, with the patient lying in a supine position.
- The smallest available telescope has a diameter of less than 2 mm.
- With this instrument, diagnostic bronchoscopy is possible even in very small newborns.
- In this case the Hopkins rod telescope alone can be inserted either by using an apnoeic technique or alternatively with the newborn breathing spontaneously.

Flexible bronchoscopes

- The flexible fiberscope consists of a flexible tube that contains a fibreoptic system that transmits an image from the tip of the instrument to an eyepiece (Figures 41.6 and 41.7).
- Another technical advance is the video scope. In these instruments, a video chip positioned at the tip of the bronchoscope replaces the glass fibre bundle.
- This design avoids the inherent susceptibility of a fibre bundle to damage.
- Digital processing of the image is also possible.
- Using Bowden cables connected to a lever at the handpiece, the tip of the instrument can be oriented, allowing the practitioner to navigate the instrument into individual lobe or segment bronchi.
- Small fibre-optic endoscopes down to 2.2 mm in external diameter are available, but these very small instruments lack a channel for suctioning and instrumentation.
- The fiberscope can be inserted through the nose or the mouth under local anaesthesia with or without sedation.
- Very young children often need deep sedation or anaesthesia.
- Otherwise, only suboptimal information can be obtained due to movement, coughing, and obstructed view.

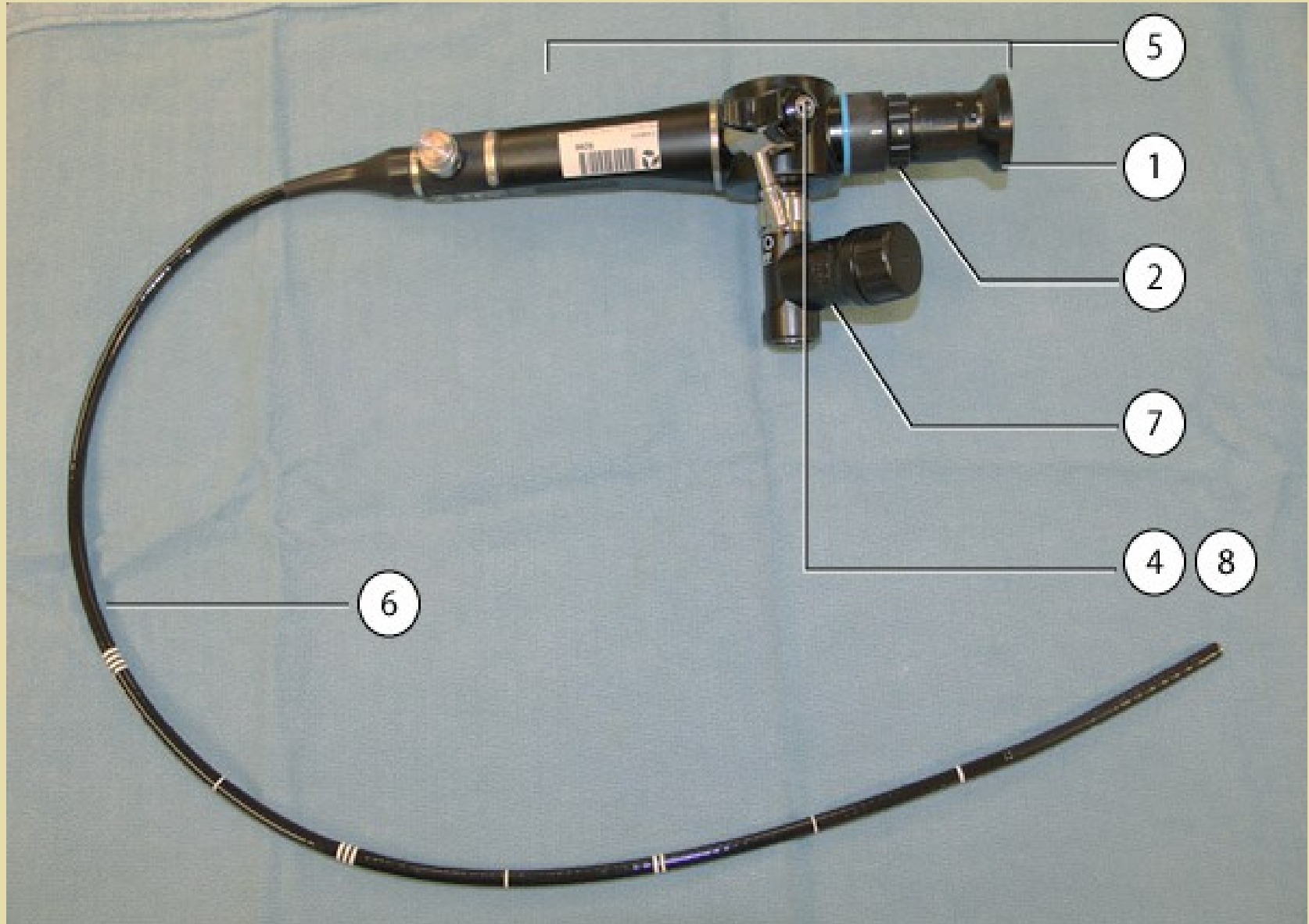

Figure 41.6: Small flexible fiberoptic bronchoscope with suction/irrigation and biopsy channel.

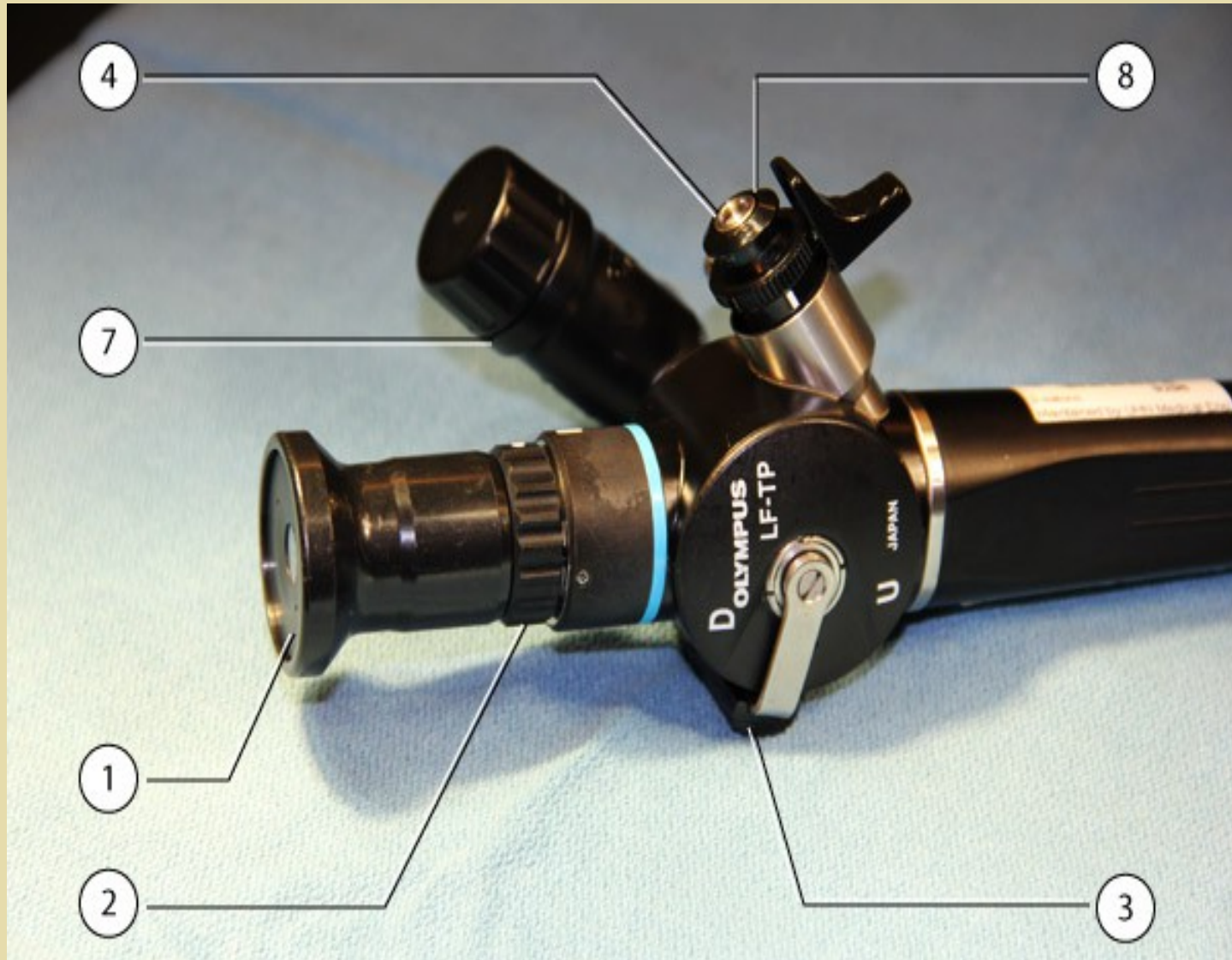

Figure 41.7: Standard flexible fibre-optic bronchoscope with full deflection, suction/irrigation channel, and biopsy channel for instruments.

Fiberoptic Bronchoscope



Fiberoptic Bronchoscope



Components

- **Eye piece:** Can be attached to a camera for display on screen. fiberoptic scopes have an eye piece; video scopes do not.
- **Diopter ring for focusing**
- **Control lever:** Controls the tip. Only permits movement in a vertical plane. Two wires extend from the handle to the tip in the insertion cord. Moving the lever down, moves the tip up and moving the lever up, points the tip down. Side to side movement is accomplished by rotation of the body of the bronchoscope with the operator's wrist and shoulder.
- **Working channel port:** For suction, instillation of local anesthetic, oxygen delivery.
- **Body:** Incorporates the eye piece, diopter ring, control level and working channel. Grasped by the operators non-dominant hand.
- **Insertion cord:** Contains fiberoptic bundle for light and image transmission, tip bending control wires and working channel. Average length 600mm (range 500 – 650mm).
- **Light source:** Can be a portable battery powered source or via a cable. Light source may be halogen, incandescent or LED.
- **Suction valve and port**

Video Bronchoscope

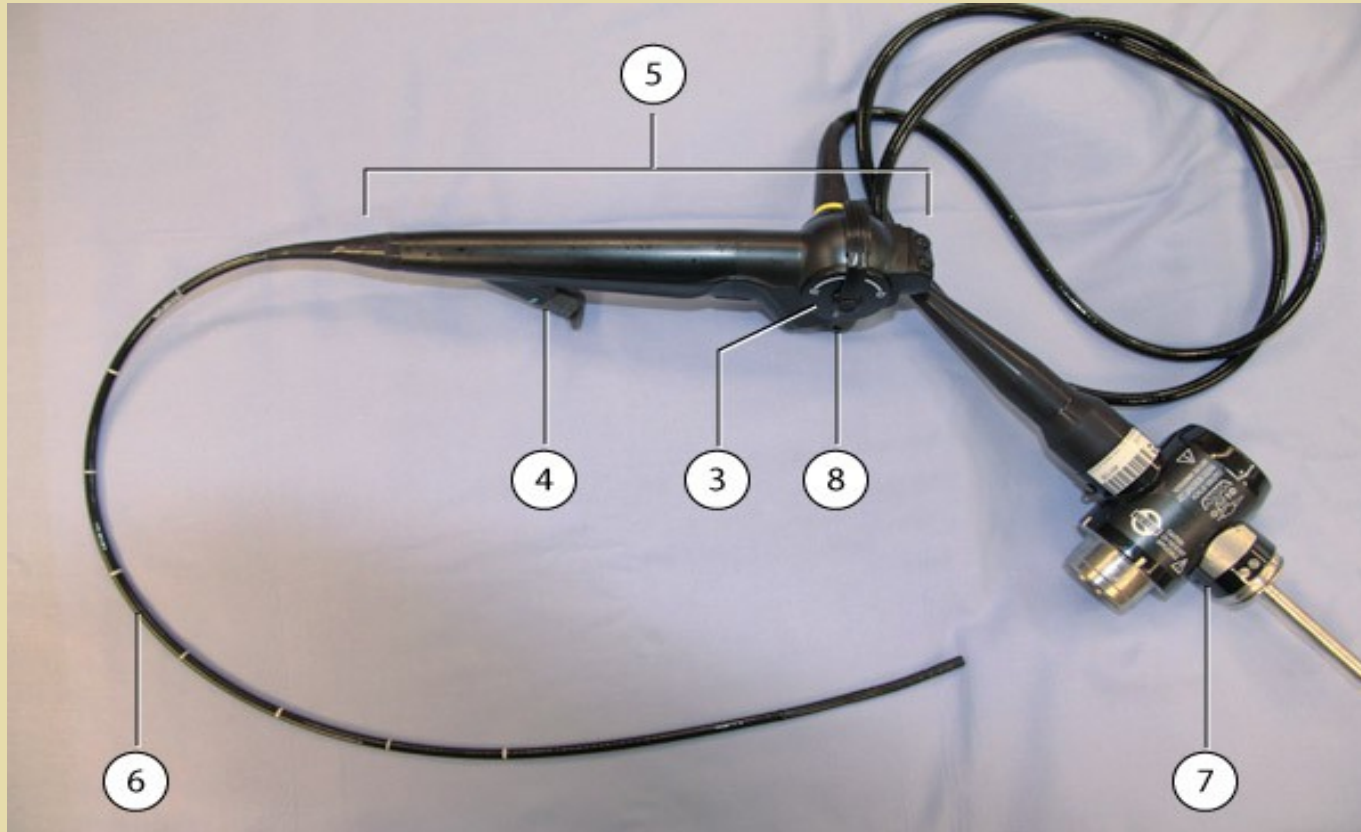

Video Bronchoscope

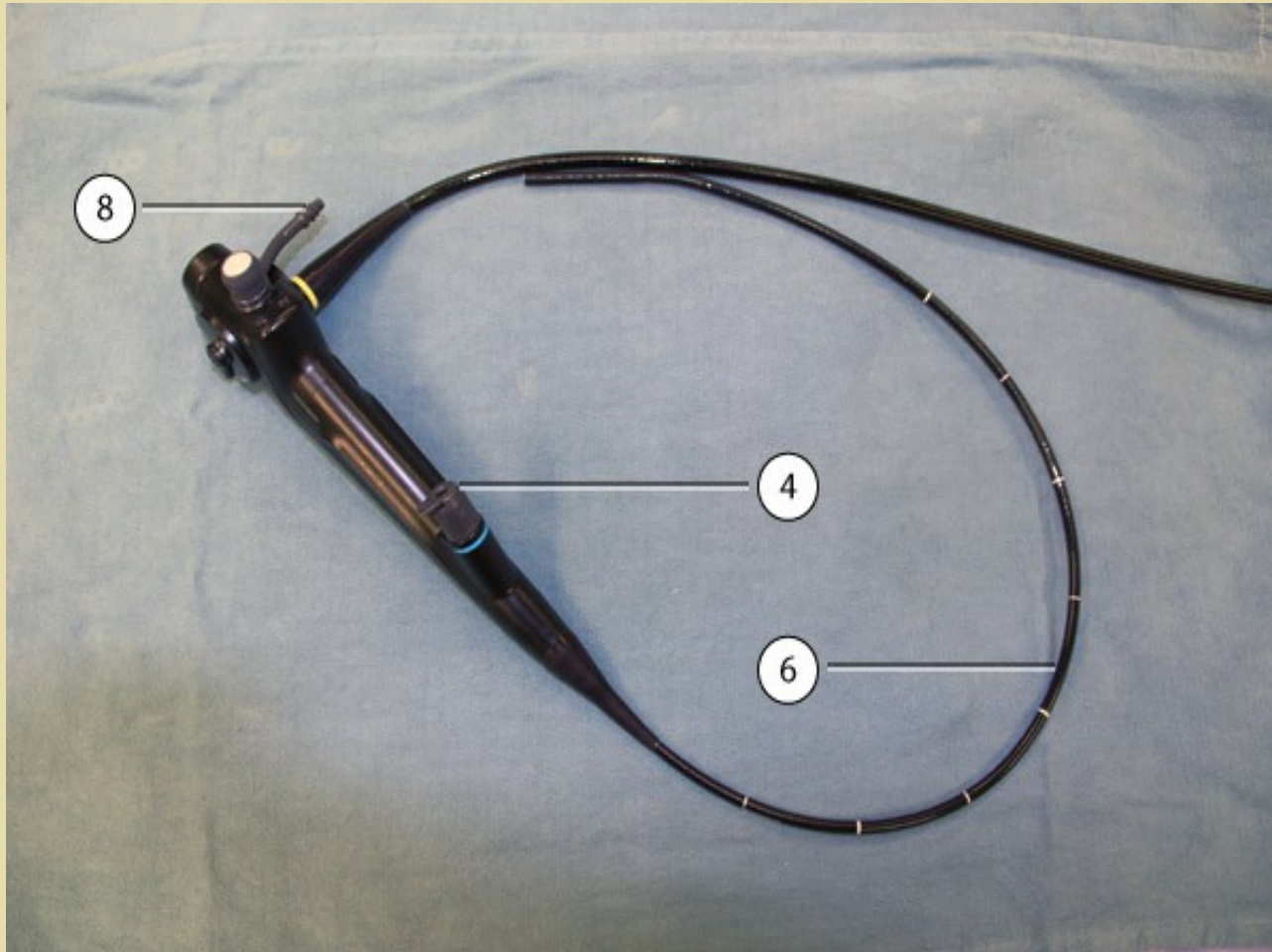

Outside diameter: Outside diameter of the insertion cord, in millimeters.

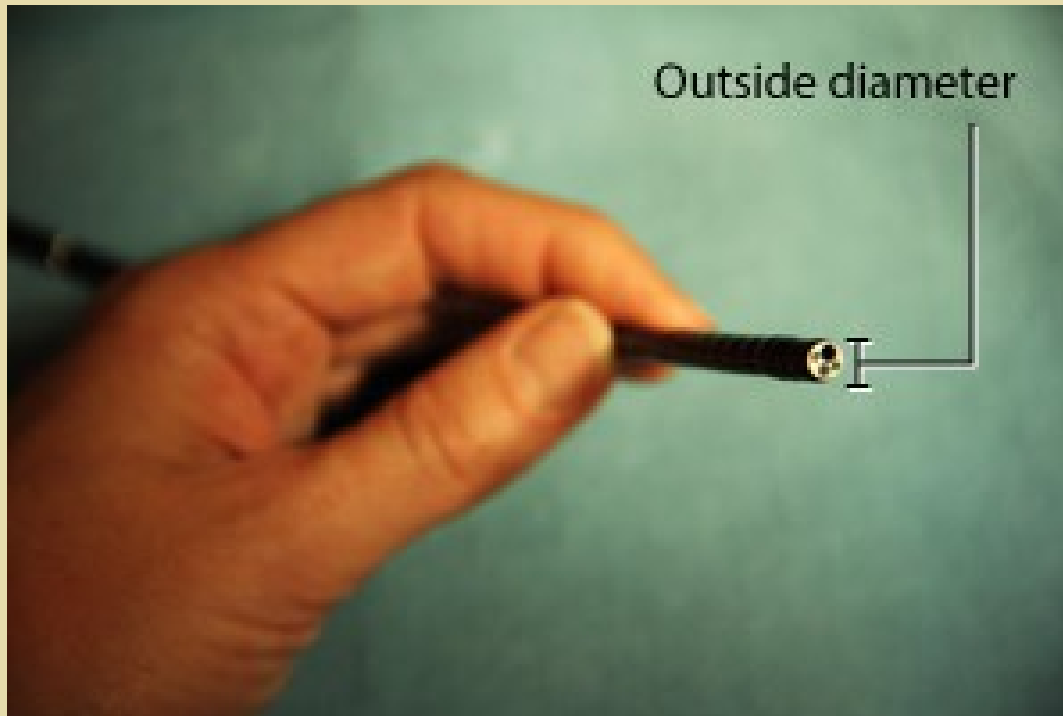

Working channel: Diameter of the working channel for suction, instillation of local anesthesia, etc.

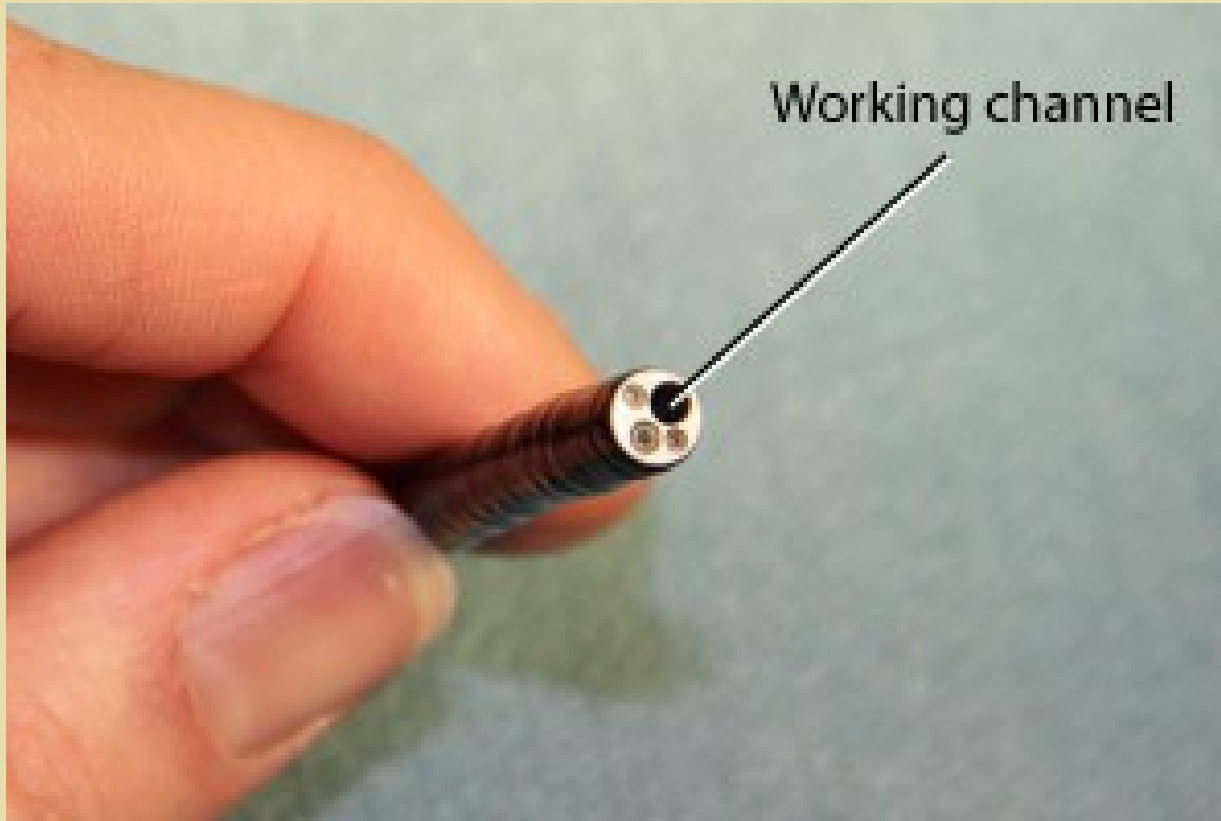

Length: Length of the insertion cord.

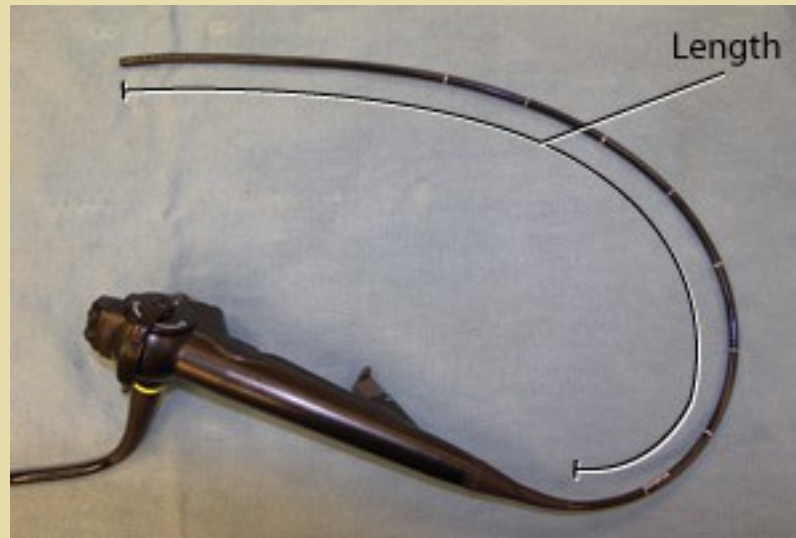

Tip Movement

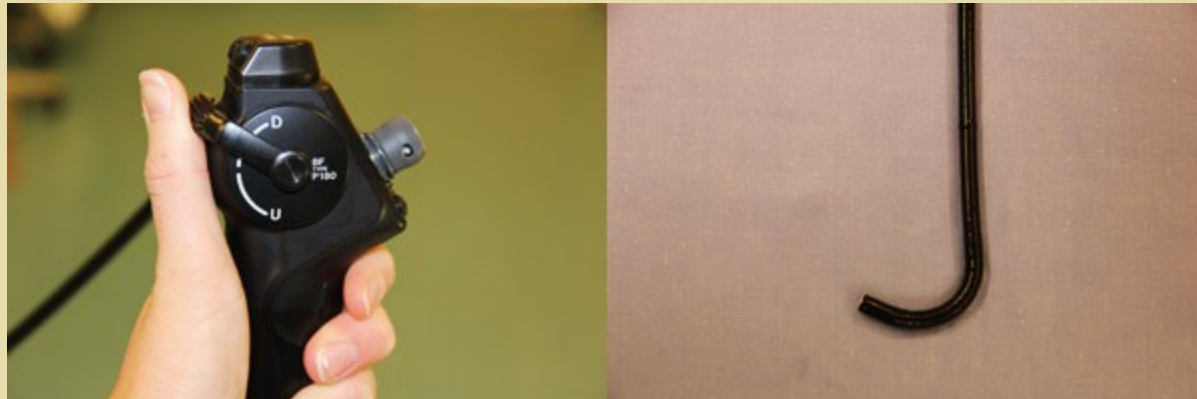
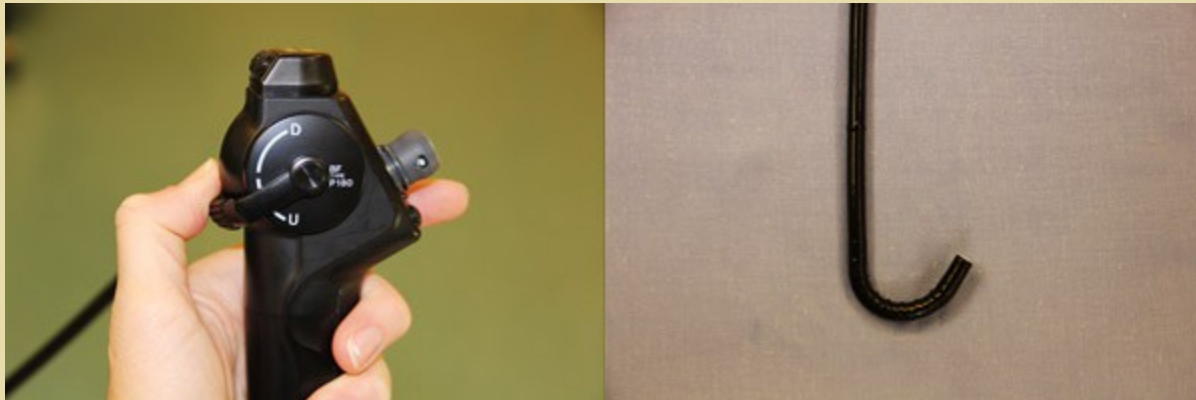

Field of view: The area that can be observed without angulation

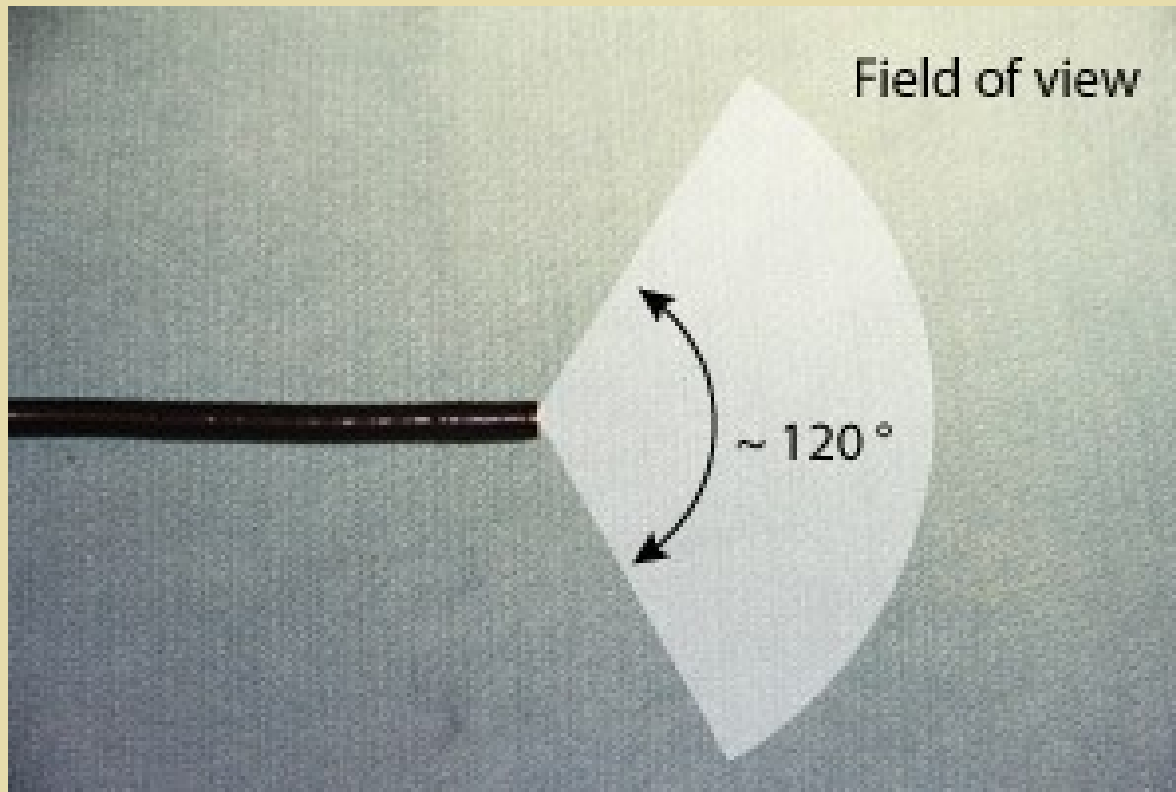

LAPOROSCOPY



Figure 1. A laparoscopic tower housing the required electronic equipment (*top to bottom*): liquid crystal display monitor, camera processor unit, insufflator, digital capture unit, and light source. A printer (*not shown*) is useful for documentation. Except for the insufflator, the equipment is identical to that used in arthroscopic surgery.

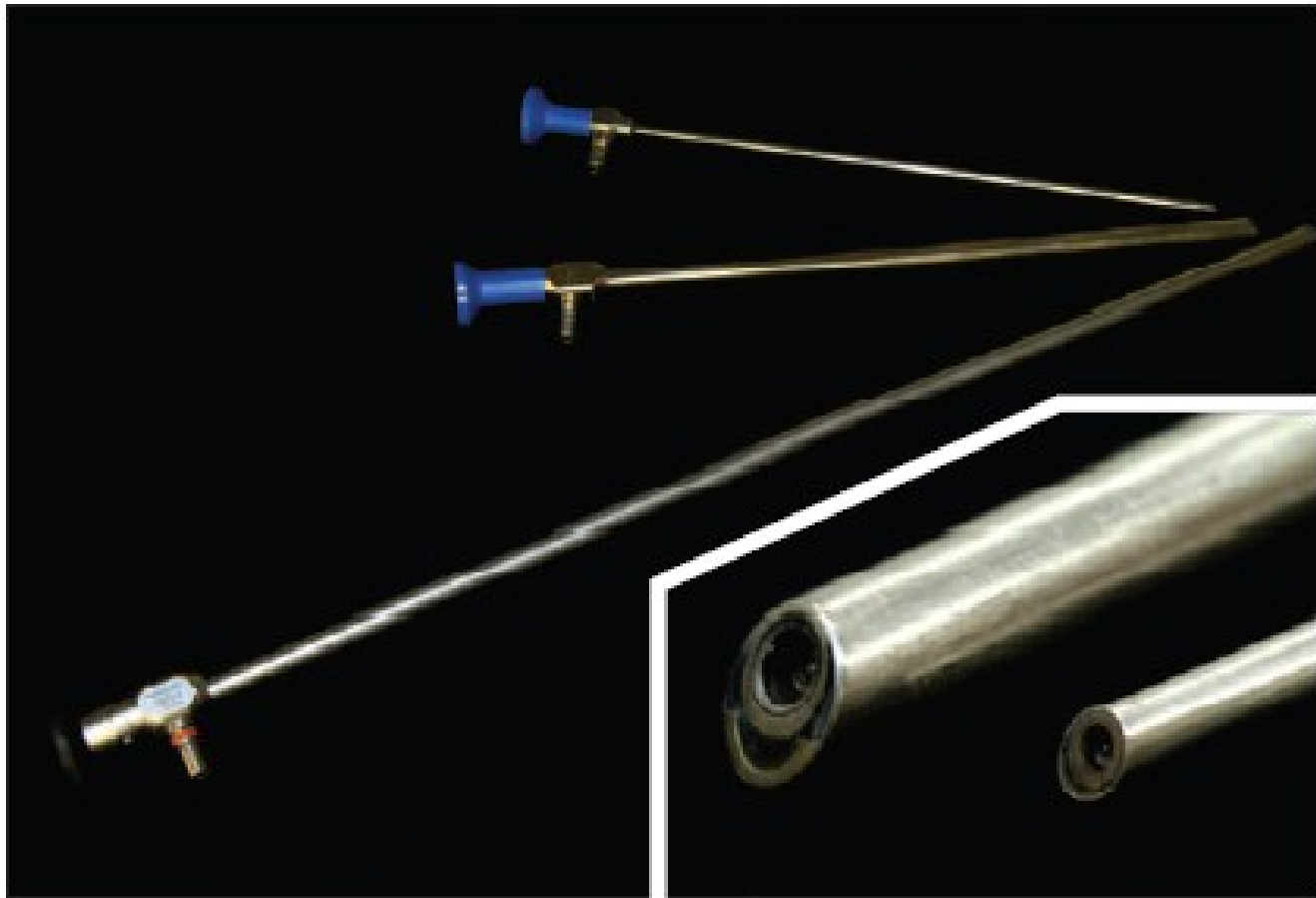

Figure 2. Laparoscopes are available in various sizes. Popular sizes include 5 mm \times 30 or 45 cm and 10 mm \times 30, 45, or 60 cm; lengths vary by manufacturer. Most laparoscopes are equipped with a 0°- or 30°-angle viewing lens. The laparoscopes shown (*top to bottom*) are 5 mm \times 30 cm, 10 mm \times 30 cm, and 10 mm \times 57 cm. *Inset.* Objective lenses (30° angle, forward viewing) of 10- and 5-mm telescopes.



Figure 3. This reusable, autoclavable, 10-mm metal cannula has an automatic trumpet valve and an attached 5-mm “flip-top” reducer valve, which permits the use of 5-mm instruments with this cannula without loss of insufflation. Below the cannula are a pyramidal trocar and a blunt obturator, which are placed within the lumen of the cannula to introduce it into the abdominal cavity. Metal cannulae are cost-effective and are preferable to plastic cannulae when monopolar cautery is used because metal cannulae reduce the chance of thermal injury due to capacitive coupling. (Most current “leaks” are conducted via the wall of a metal cannula to a relatively large area of tissue in the abdominal wall, reducing the risk of current discharge by arcing to an unknown intraabdominal location).



Figure 4. A disposable plastic cannula. While this type of cannula is convenient and is available in various sizes, including relatively large ones (e.g., 15 to 18 mm), it is expensive and is difficult to sterilize.



Figure 5. A hybrid cannula. The valve assembly (*shown in two parts*) is disposable and is equipped with a silicone leaflet valve (blue “bicuspid” valve), which is less prone to trap suture loops than conventional trumpet valves. The cannula (*foreground*) and the conical obturator (*background*) are autoclavable.

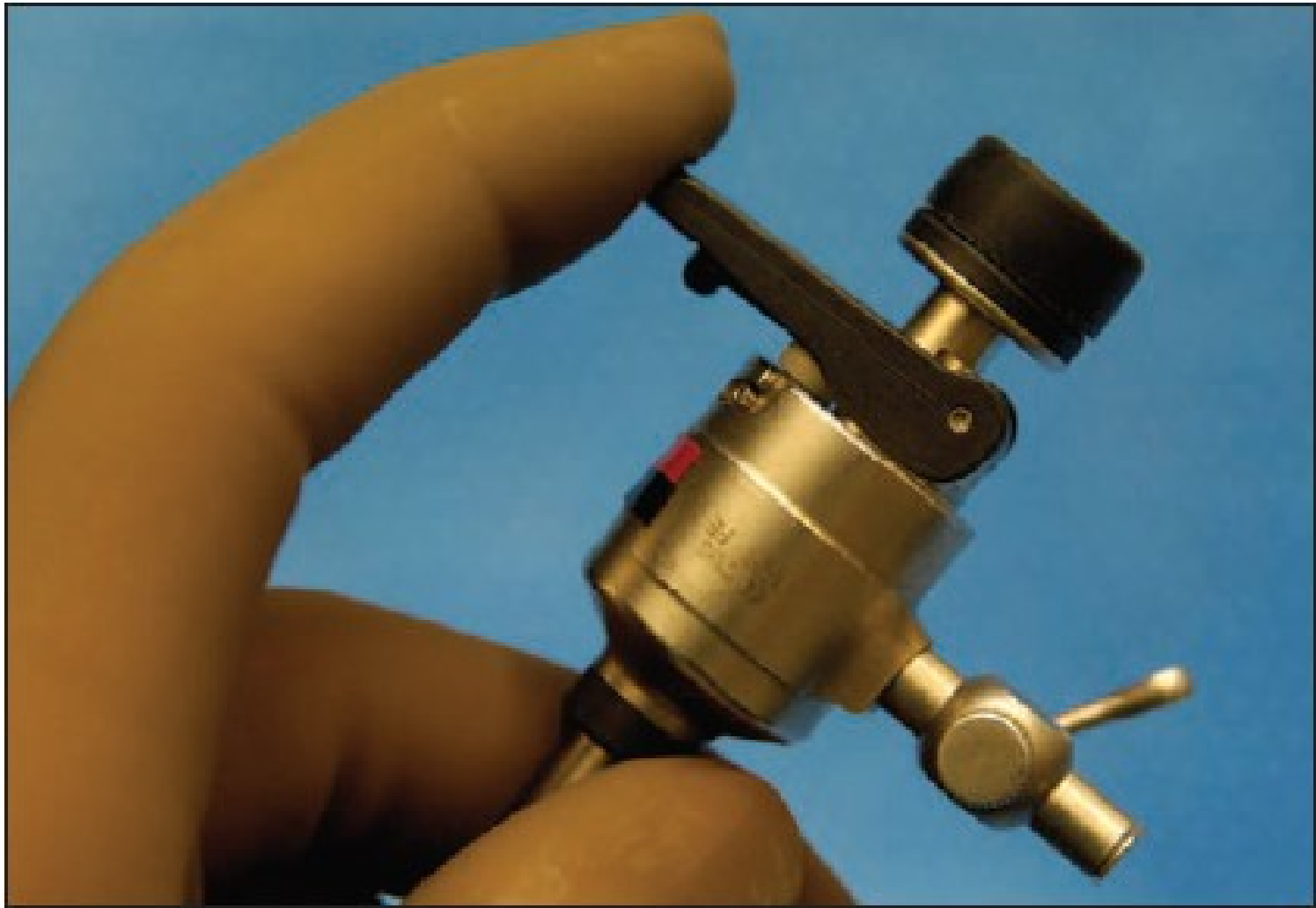

Figure 6. A 5-mm cannula equipped with a multifunctional valve assembly. The spring-loaded valve can be manually opened by depressing the lever as shown. This type of cannula has the advantage of allowing the introduction and removal of sharp instruments without dulling them or damaging the rubber ring lining the valve flap.



Figure 7. An insufflator is required to create pneumoperitoneum. A high-flow capacity unit is ideal; flow rates of at least 20 L/min are required to insufflate the voluminous equine abdomen in a timely fashion. The digital readouts include desired/actual intraabdominal pressure (10 mm Hg), insufflation rate (20 L/min), and CO₂ consumed (4.8 L).



Figure 8. Assorted 5-mm hand instruments. *Left to right:* Dorsey forceps, Babcock forceps, Kelly forceps, retention grasping forceps, right-angle forceps, Metzenbaum scissors, and suture-cutting (hook) scissors.



Figure 9. A three-chip camera attached to a laparoscope. Care should be taken to keep the camera upright (i.e., controls facing upward) at all times, even when the laparoscope is rotated to vary the field of view in the abdomen.

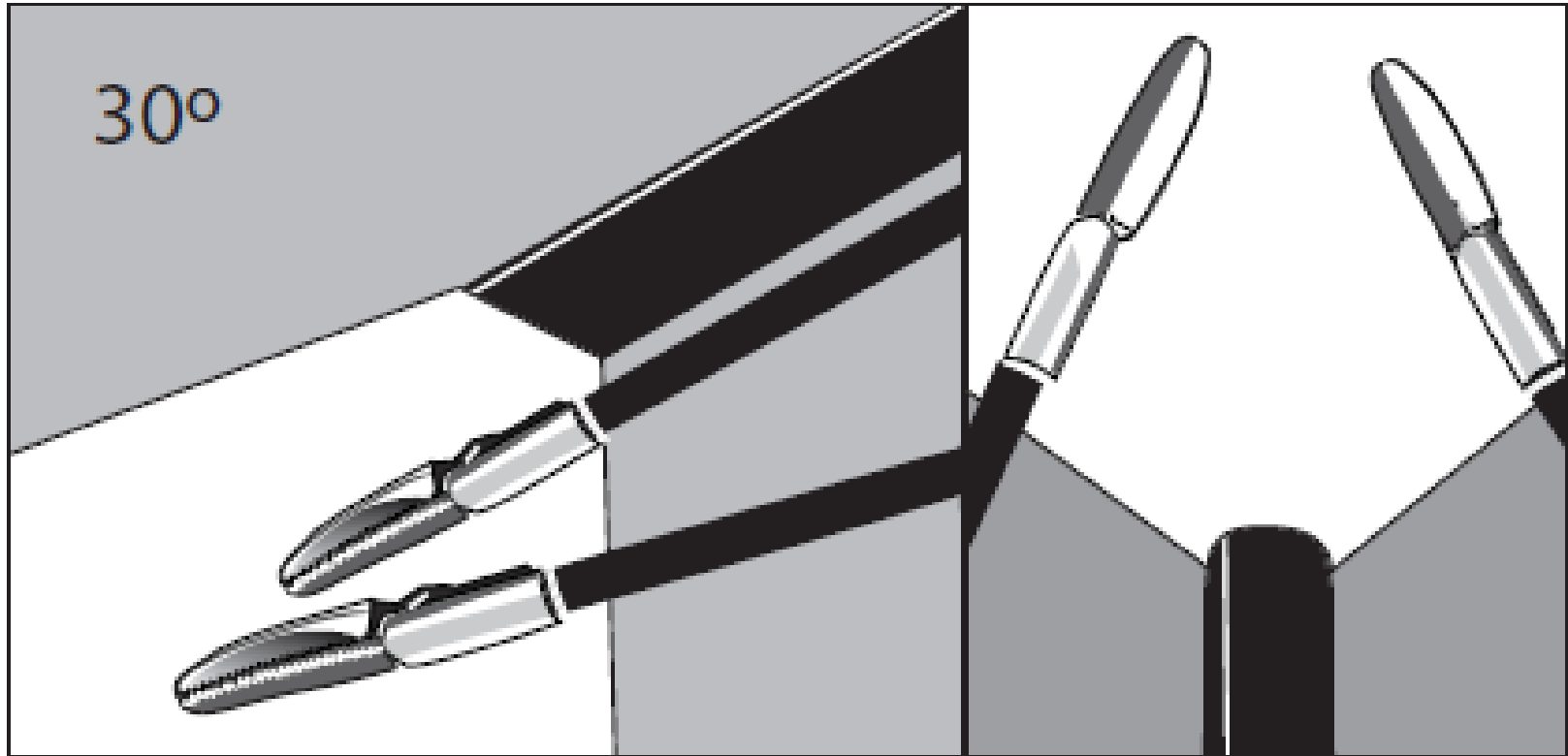

Figure 10. Diagrammatic representation of the arrangement of a 30°-angle laparoscope and two hand instruments. The approach angle of the laparoscope reduces interference with instrument manipulations.

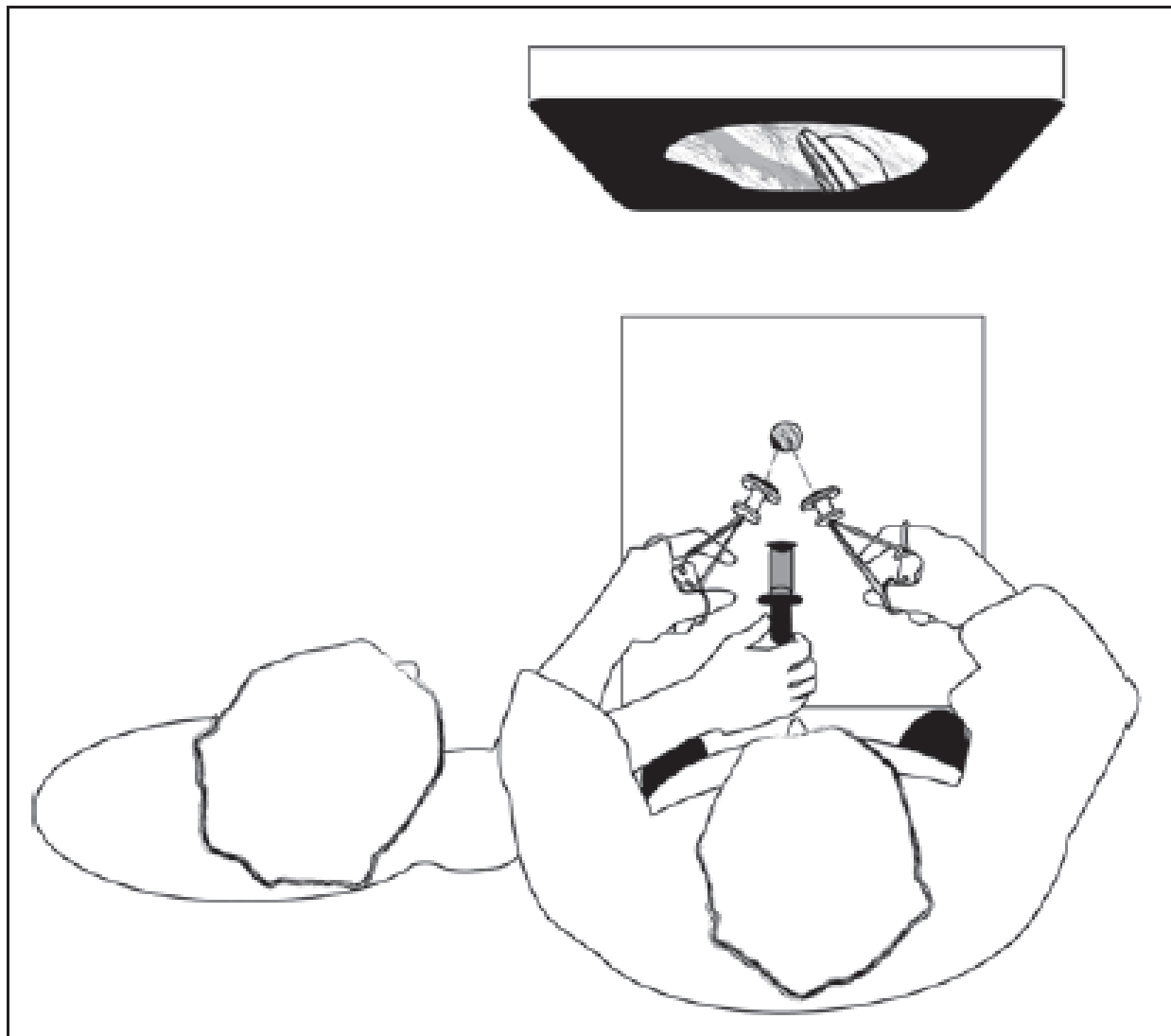

Figure 12. Diagram illustrating triangulation and optical-coaxial alignment. Triangulation involves convergence of the telescope and instruments approximating the shape of an isosceles triangle. A direct line formed by the surgeon, telescope, and instruments toward the monitor (optical-coaxial alignment) is comfortable and avoids (1) paradoxical movement associated with the telescope or (2) reverse camera (direction of an instrument toward the surgeon).

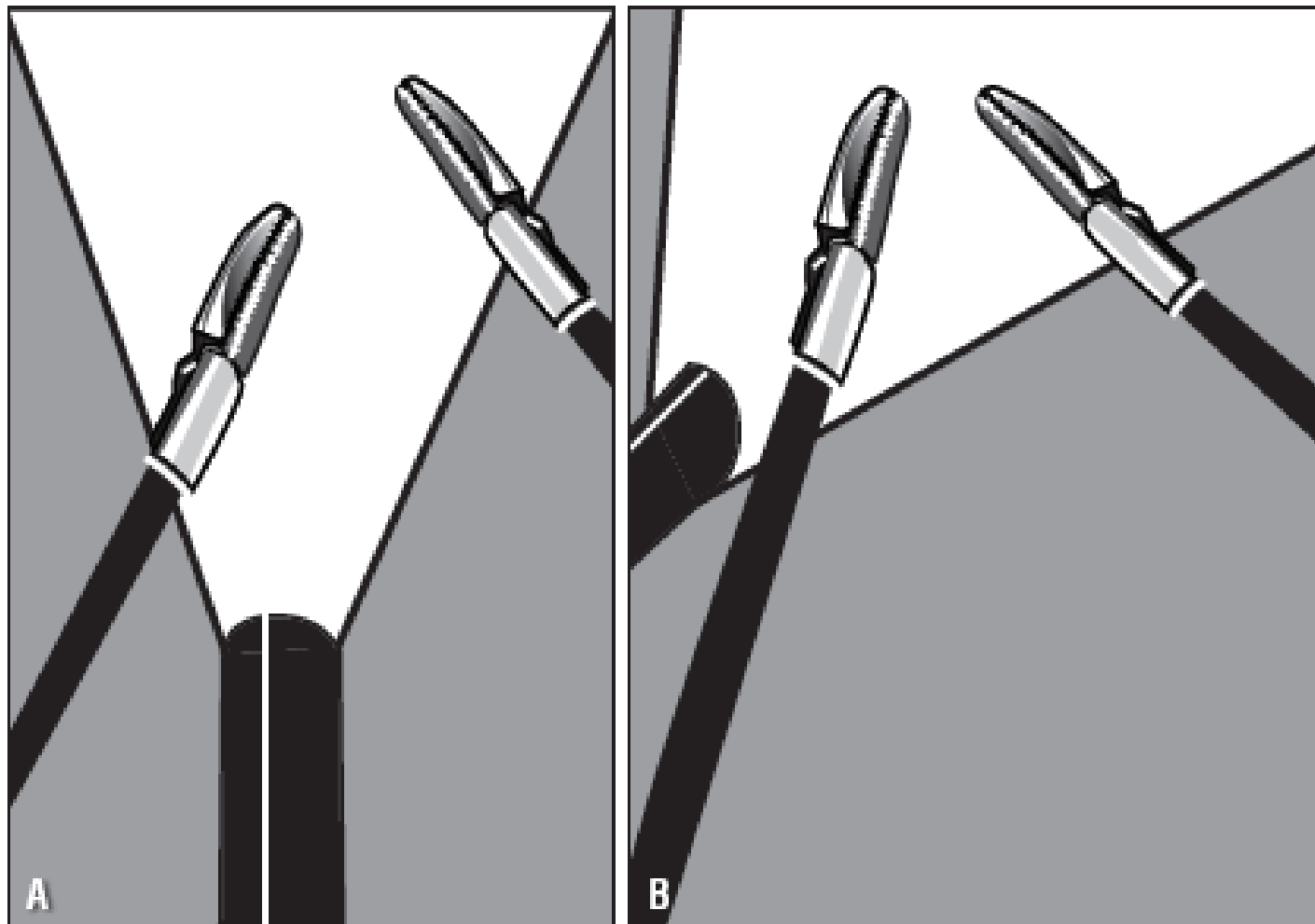

Figure 13. Diagrams illustrating (A) conventional placement of a laparoscope in a central position with the instruments to each side and (B) placement of a telescope to the side of a pair of instruments. Arrangement A should be used when possible to maximize efficiency and visibility. In arrangement B, the instrument on the far right can be obscured by the intervening one, potentially reducing efficiency.

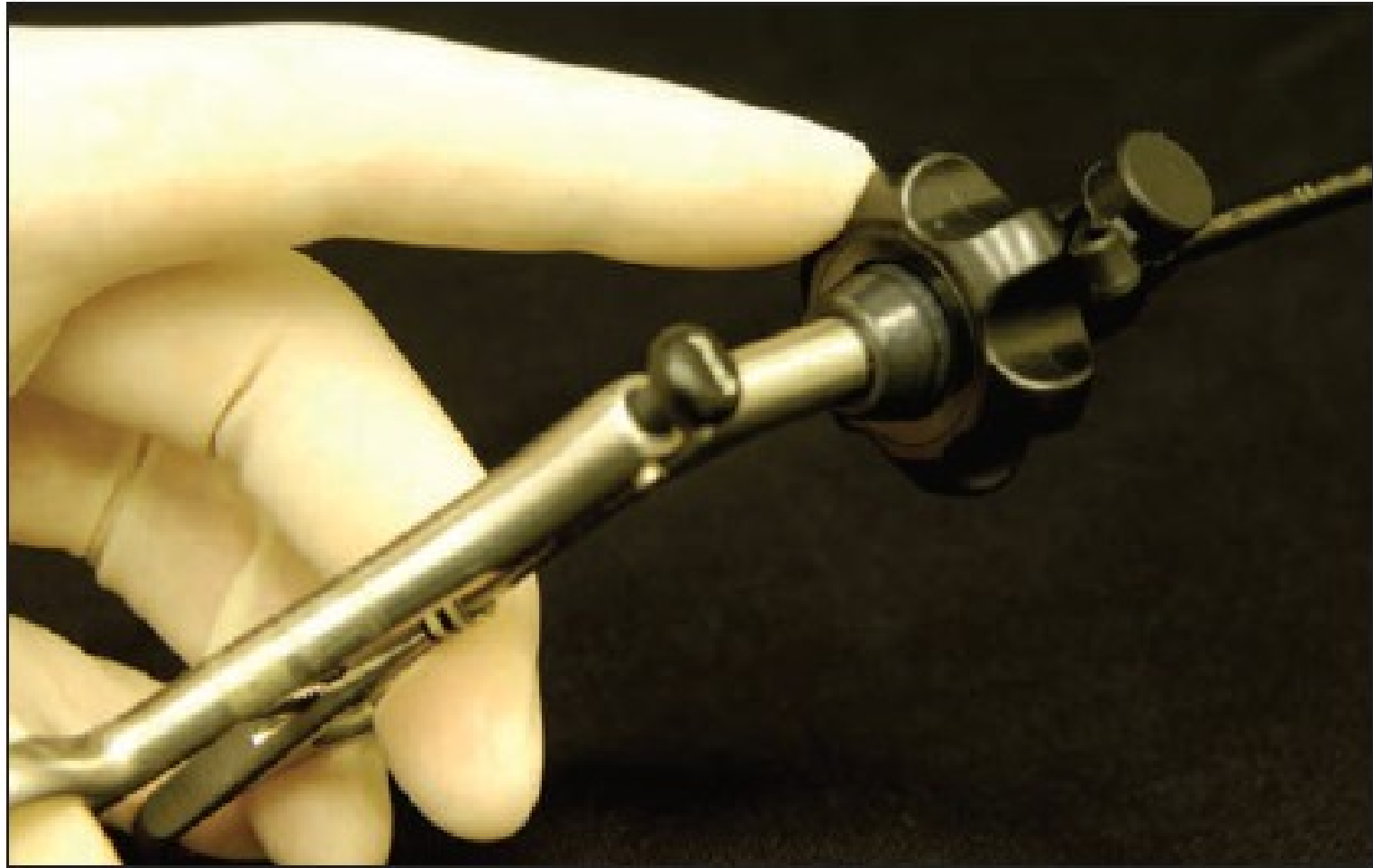

Figure 14. Laparoscopic handpiece with a control wheel that permits rotation of the instrument on its long axis. Adjusting the orientation of the working portion of the instrument is vital to efficient and atraumatic tissue handling. Beginning laparoscopists commonly overlook this feature on many hand instruments.

References

- Equine Laparoscopy: Equipment and Basic Principles By John P. Caron, DVM, Michigan State University, vet learn.com
- “Laryngoscopy, Bronchoscopy, and Oesophagoscopy” Chapter 41 , By V. T. Joseph, Michael Laschat, Catharine Mngongo
- https://www.blackwellpublishing.com/xml/dtds/4-0/help/10003420_chapter_1.pdf